

Part Number: PTS20-21050

Kit Contents

Item #	Quantity Reqd.	Description
1	1	Vehicle Specific Enclosure (VSE) Subwoofer
2	1	Wire Harness
3	1	Hardware Bag
4	1	Installation Instructions
5	1	Product Feature Placard
6	1	Service Care Card

Hardware Bag Contents

Item #	Quantity Reqd.	Description
1	5	7/16 Wire Ties
2	8	Philips Head Screws
3	1	Upper Mounting Hardware Assembly
4	1	Lower Mounting Hardware Assembly

Additional Items Required For Installation

Item #	Quantity Reqd.	Description
1		

Conflicts

SCION tC Cargo Net PN: PT347-52051

Recommended Tools

Personal & Vehicle Protection	Notes
Vehicle Protection	Seat/Floor Covers
Part Protection	Blankets
Special Tools	
Arch Punch	5/8 Hole Diameter (McMaster PN: 3427A17)
Mallet	Rubber Mallet
Screwdriver	1.5 Long Narrow Blade Flat Head (Craftsman PN: 41541 or equivalent)
Installation Tools	
Nylon Panel Removal Tool	e.g. Panel Pry Tool #1 Toyota SST # 00002-06001-01
Socket/Ratchet	10mm, 12mm & 13mm
Socket Extension	6 inch (optional)
Ratcheting Box End Wrench	13mm
Torque Wrench	3 lbf-ft , and 15 lbf-ft
Pliers	1. Diagonal Cutters 2. Long Nose (optional)
Screwdriver	Magnetized Philips # 2

NOTE: Part number of this accessory may not be the same as the part number shown.

Electric Drill	Philips # 2 Drill Bit
Special Chemicals	Notes
Cleaner	3M™ Prep Solvent 70 (if required)

General Applicability

ALL SCION tC

Recommended Sequence of Application

Item #	Accessory
1	Security / Audio / Satellite Tuner
2	Rear Cargo Mat / Cargo Liner
3	VSE Subwoofer
4	Door Sills

*Mandatory

Vehicle Service Parts (may be required for reassembly)

Item #	Quantity Reqd.	Description
1		

Legend

 **STOP:** Damage to the vehicle may occur. Do not proceed until process has been complied with.

 **OPERATOR SAFETY:** Use caution to avoid risk of injury.

 **CAUTION:** A process that must be carefully observed in order to reduce the risk of damage to the accessory/vehicle and to ensure a quality installation.

 **TOOLS & EQUIPMENT:** Used in Figures calls out the specific tools and equipment recommended for this process.

 **REVISION MARK:** This mark highlights a change in installation with respect to previous issue.





VSE Subwoofer Specifications

Woofers Size	10 Inch
Voice Coil Size	1.5 Inch
Magnet Size	34 oz
Frequency Response	28Hz-100Hz +/-3dB
Efficiency	96 dB
Power Handling	150 watts (woofer)
Dimensions	745mm x 390mm x 370mm
Weight	22 lbs
Impedance	Dual 2 Ohms

Care must be taken when installing this accessory to ensure damage does not occur to the vehicle. The installation of this accessory should follow approved guidelines to ensure a quality installation.

These guidelines can be found in the "Accessory Installation Practices" document.

This document covers such items as:-

-  Vehicle Protection (use of covers and blankets, cleaning chemicals, etc.).
-  Safety (eye protection, rechecking torque procedure, etc.).
-  Vehicle Disassembly/Reassembly (panel removal, part storage, etc.).
-  Electrical Component Disassembly/Reassembly (battery disconnection, connector removal, etc.).

Please see your Toyota dealer for a copy of this document.

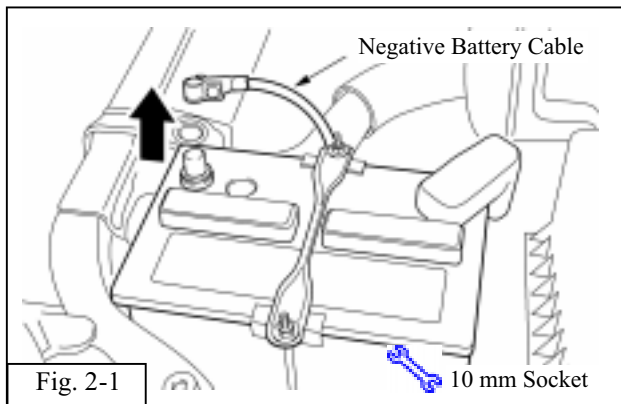

1. Pre-installation Precautions

-  (a) Use Seat & Floor Protectors and Fender Covers/Blankets to avoid damage to surfaces.

2. Battery Disconnect

-  (a) NOTE: Be sure to open the rear hatch, **PRIOR** to disconnecting the battery.
- (b) For vehicles equipped with automatic transmission, place the shifter in the N (neutral) position and set the parking brake prior to disconnecting the battery.
- (c) Remove the NEGATIVE (-) battery terminal using a 10mm socket before any disassembly starts. (Fig. 2-1)

3. Disassemble Rear Cabin Interior Components

NOTE: ALL INTERIOR COMPONENTS THAT ARE REMOVED FROM THE VEHICLE MUST BE PLACED ON A CLEAN & PROTECTED SURFACE (i.e. Blanket)

- (a) Starting at the rear of the vehicle, remove and secure the rear Tonneau Cover.
- (b) Proceed to unlock the two (2) knob locks and remove and secure the rear Cargo Floor panel & floor mat (if equipped).
- (c) Proceed to remove and secure the rear cargo entry scuff plate by pulling upwards.(Fig. 3-1)

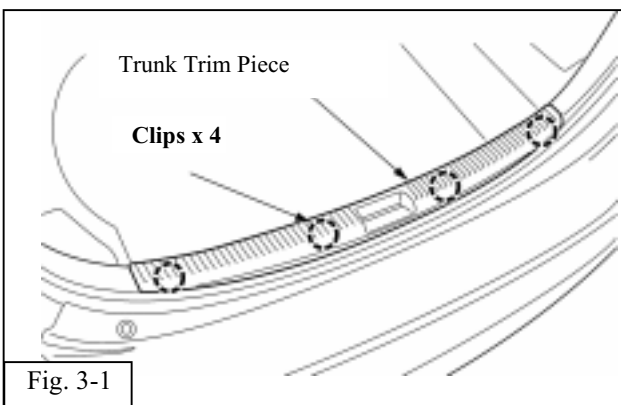

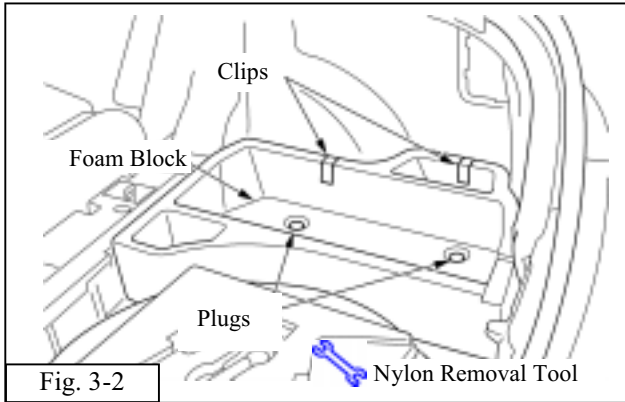

- (d) Proceed to remove and secure the rear foam passenger side storage compartment.
 - (1) Remove the two (2) plastic plugs and pull the block straight up. (Fig. 3-2)

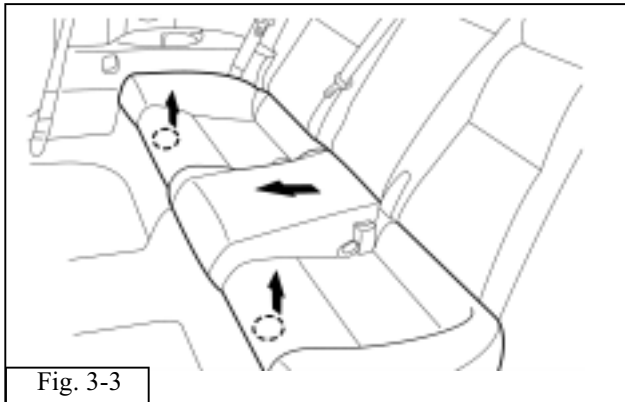

- (e) Proceed to remove and secure the rear bench seat, by pulling upwards on each corner, to release the two (2) mounting clips. (Fig. 3-3)
- (f) Using the 2 release handles, lower the driver and passenger side rear seat backs.

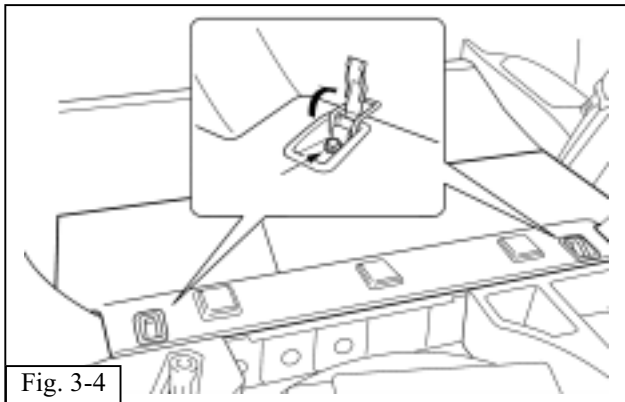

- (g) Using the NRT, release the plastic bolt covers from the two (2) D-Ring holders. (Fig. 3-4)
 - (1) Using the 10mm socket, remove the two (2) 10mm D-Rings.

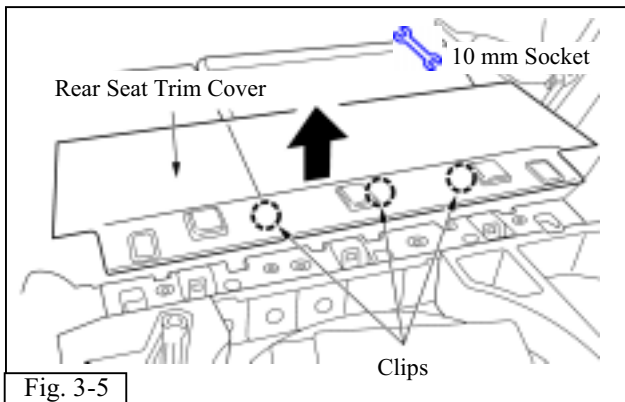

- (h) From the center of the rear seat trim cover, unsnap and remove panel. (Fig. 3-5)

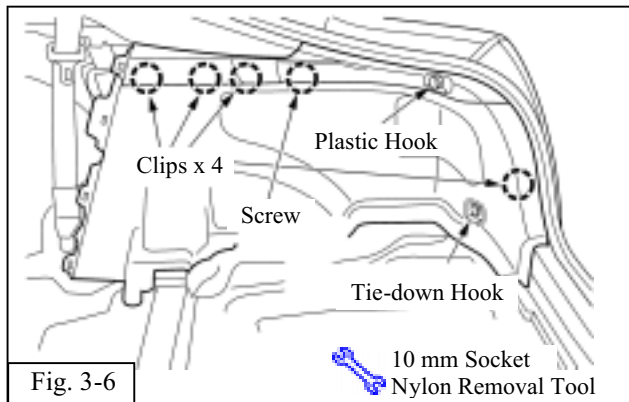

- (i) Using a 10mm socket, remove the passenger rear D-Ring (Tie Down Hook) (discard) and save the 10mm bolt for reuse. (Fig. 3-6)
- (j) Remove and save, the Philips head screw from the upper rear passenger panel & save for reuse. (Fig. 3-6)
- (k) Remove & discard passenger rear taillight access panel. (Fig. 3-6)
- (l) Using the 1.5" narrow blade flat head screwdriver, gently insert into the passenger plastic cargo net hook & rotate to remove. (Fig.3-6 and 3-7)
- (m) Gently release the lower portion of rear passenger side trim, then using a NRT, gently pry off the rear cargo passenger side inner panel.

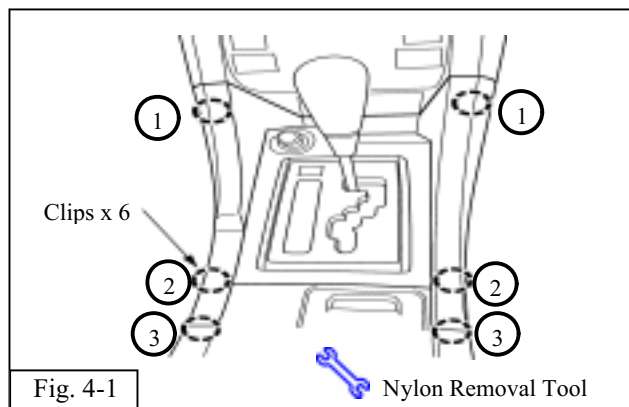
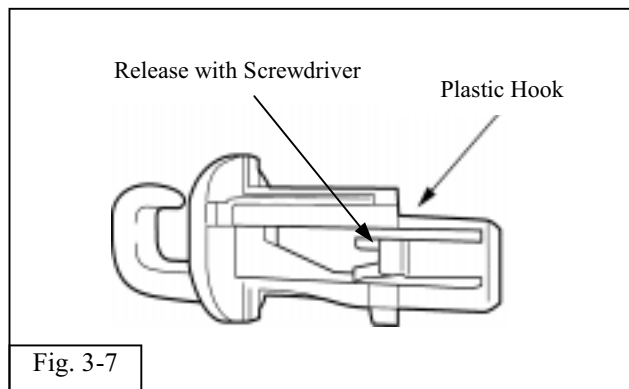

4. Disassemble Front Cabin Interior Components

- (a) Unscrew OE Shift Knob Counter-Clockwise until OE Shift Knob is removed.
- (b) Confirm the shifter is in the neutral position.
- (c) Remove the six (6) shift surround console clips, in the order shown. (Fig.4-1)
 - (1) Disconnect the cigarette lighter wire harness from underneath the shift surround console prior to removal.
- (d) Remove the nine (9) Upper Center Instrument Panel (IP) clips, in the order shown. (Fig.4-2)
 - (1) Make sure the radio cover door is closed.
 - (2) Disconnect the center IP main harness from the backside of the center IP prior to removal.

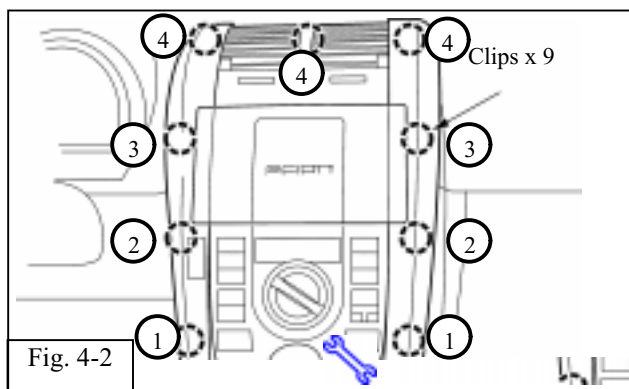

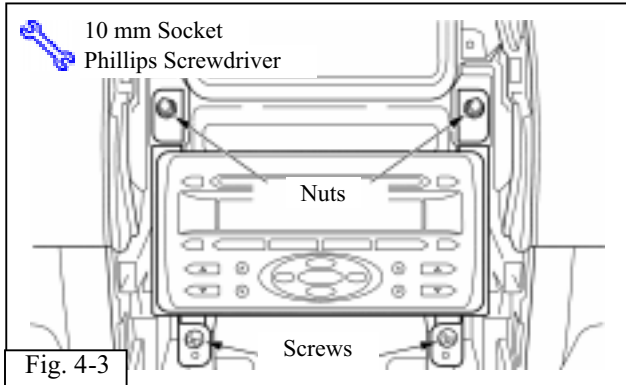

(e) Remove the radio unit, by removing the two (2) top 10mm nuts and two (2) bottom Philip head screws from the radio bracket. (Fig.4-3)

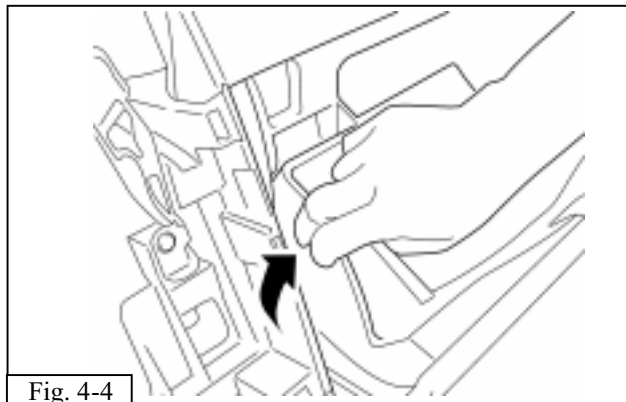

(f) Open the glove compartment latch and press the outside edges of the glove compartment inwards, to remove. (Fig.4-4)

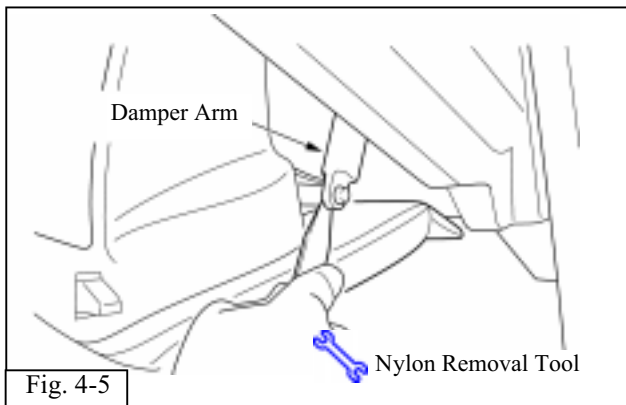

(1) Detach the glove compartment damper, and remove the lower glove box panel prior to removal. (Fig.4-5)

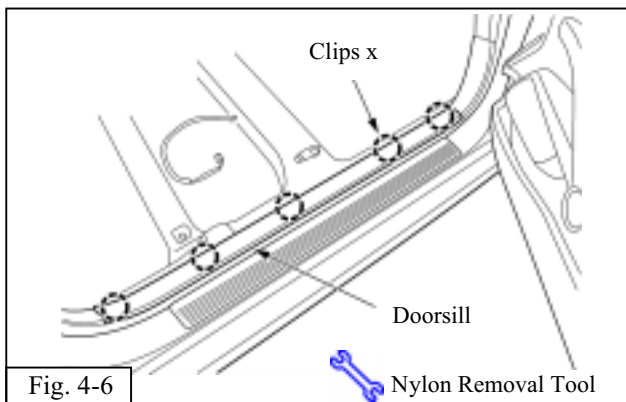

(g) Using a NRT, remove passenger front scuff plate by carefully pulling upward. (Fig.4-6)

(1) **NOTE:** If a clip remains on the vehicle, remove it and replace it back into the plastic doorsill cover.

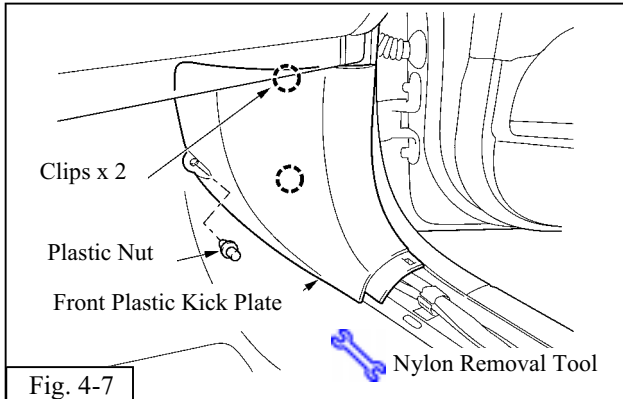

- (h) Remove passenger kick panel by removing the plastic screw (located near firewall) & pulling out the kick panel. (Fig.4-7)

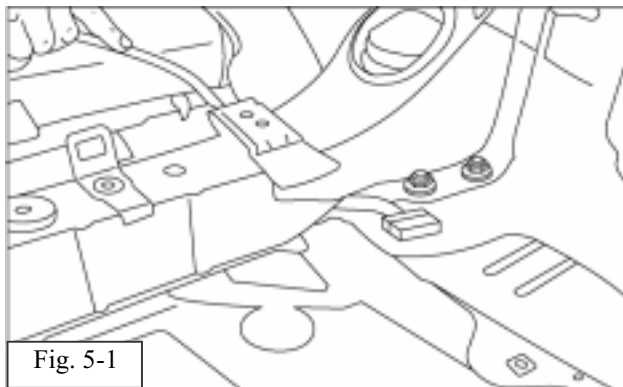

5. Routing Wire Harness

- (a) Starting at the rear of the vehicle, route the pig tail end underneath the rear strut reinforcement access panel, and route towards rear passenger side taillight. (Fig.5-1)

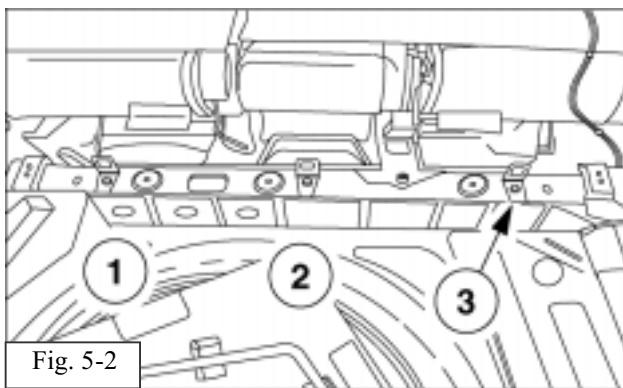

- (b) Using the 12mm socket, remove the #3 Child Restraint bracket bolt, & re-install ground ring underneath bolt. (Fig.5-2)

 (1) Torque bolt to 31 lbf·ft (42 N·m)

- (c) Run the T-Harness portion of the W/H forward between the passenger seat bracket and inner wheel well. (Fig.5-3)

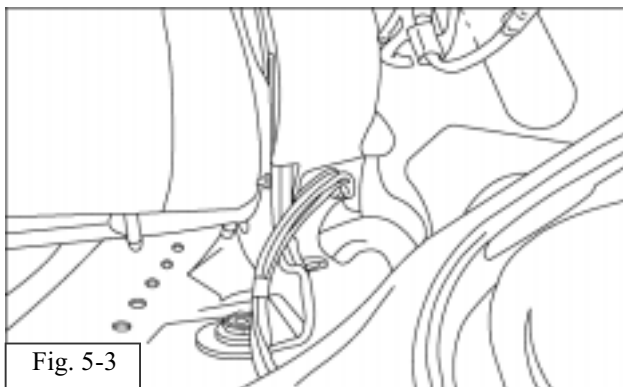

- (d) From inside the back seat, route W/H behind seat belt & tuck under the rear passenger speaker / cup holder panel.

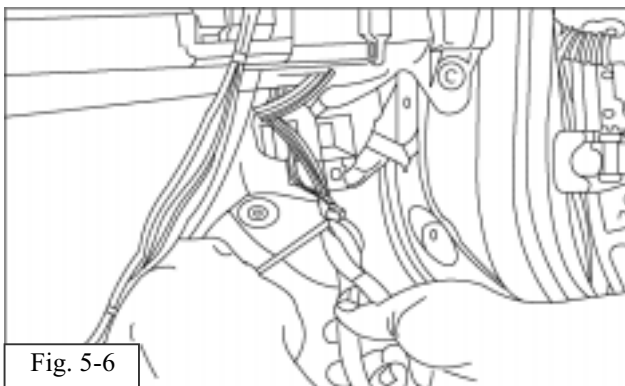
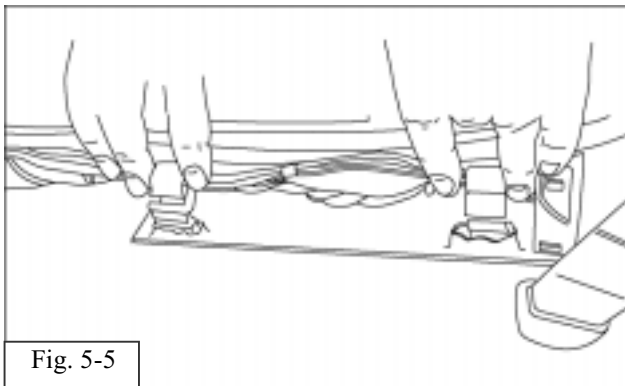
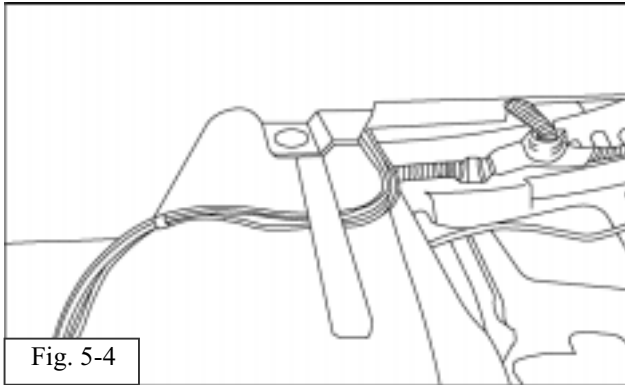

(e) Using a NRT, remove the panel-fastening clip. (Fig.5-4)

(1) Proceed to route the wire harness underneath clip tab, and back underneath panel, with the T-Harness portion of the wire harness exiting at the passenger side entry way.

(f) Route wire harness forward through existing vehicle-accommodated clips. (Fig 5-5)

(g) Attach wire harness with two (2) 7/16 wire ties at well. (Fig.5-6)

(1) Using the diagonal cutter pliers, clip the 7/16 wire ties. (Fig.5-6)

(h) Route wire harness up behind the dash and secure wire harness to the dash reinforcement bar using two (2) 7/16 wire ties.

(1) Using the diagonal cutter pliers, clip the 7/16 wire ties. (Fig.5-7)

(i) Route remaining wire harness towards radio opening and attach harness to the vertical dash reinforcement using one (1) 7/16 wire tie.

(1) Using the diagonal cutter pliers, clip the 7/16 wire tie.

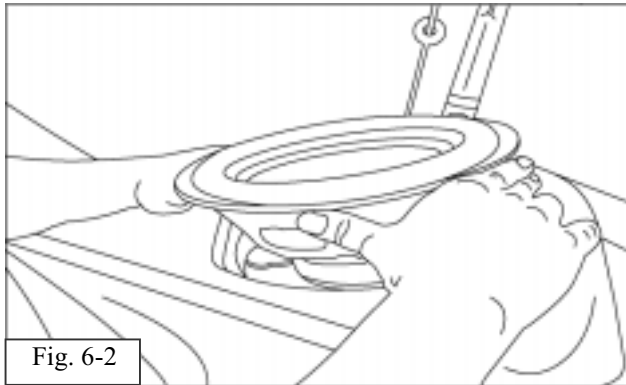
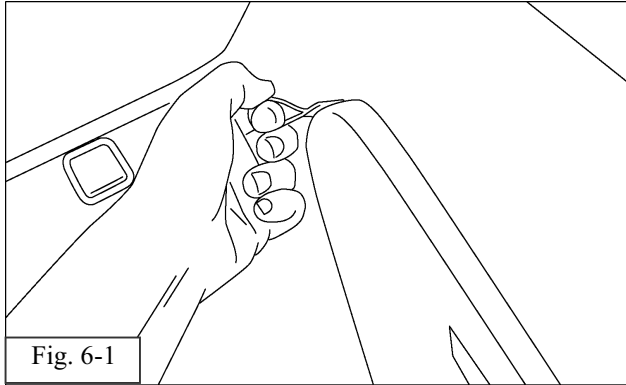

6. Prepare VSE Subwoofer for Installation

NOTE: ALL SUBWOOFER COMPONENTS THAT ARE REMOVED MUST BE PLACED ON A CLEAN & PROTECTED SURFACE (i.e. Blanket)

- (a) Carefully remove the front screen of the enclosure by pulling on the removal tab. (Fig.6-1)
- (b) Remove the four (4) Philips screws and save for reuse.
- (c) Carefully remove the 10mm driver. (Fig.6-2)

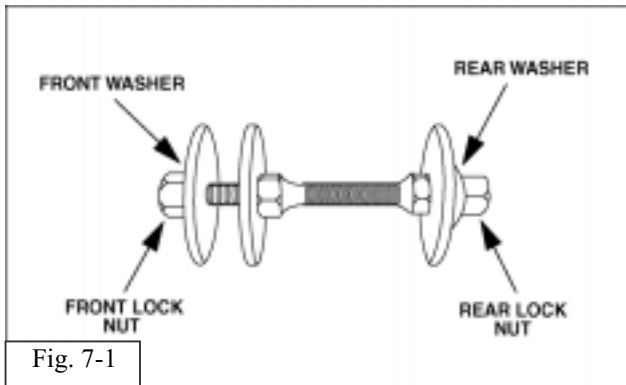

7. Modify Rear Inner Quarter Panel

- (a) Prepare the upper hardware assembly by removing the front lock nut & first front washer (leaving the second front washer installed). Then remove the back lock nut and flat washer. (Fig.7-1)
- (b) Install the hardware assembly through the front side of the accommodation hole located on the lower inner sheet metal panel; secure the hardware assembly by fastening the back flat washer and lock nut using a 13mm ratcheting box end wrench or socket from behind the inner sheet metal panel. (Fig.7-2)
 - (1) Make sure antenna wire harness runs underneath hardware assembly (Fig.7-2)
- (c) With the upper hardware assembly installed, index the outer rear quarter panel by positioning panel over the hardware stud and

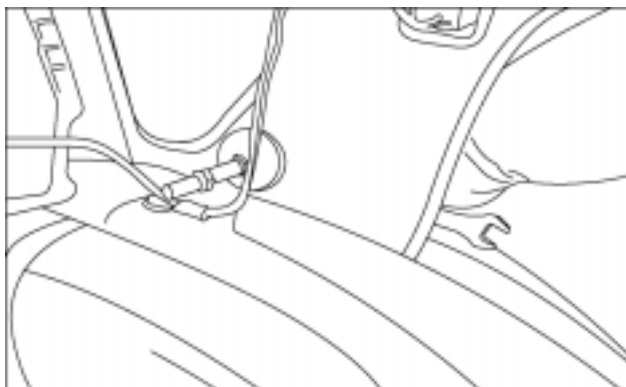

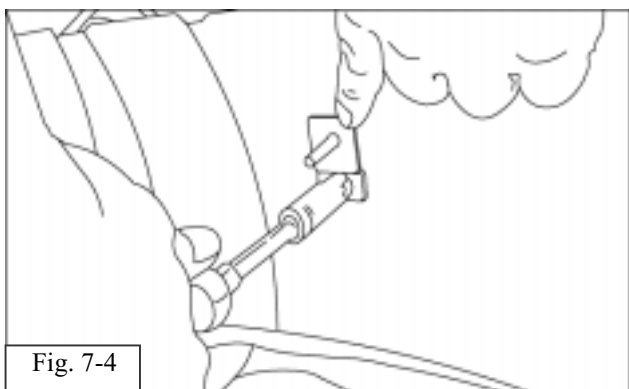
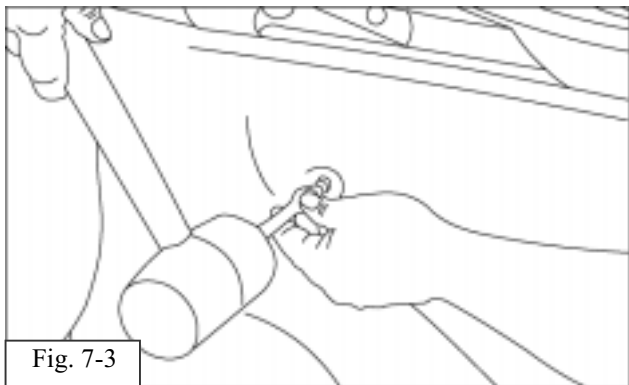

use the 5/8" Hole Punch & Mallet to punch a hole through the panel. (Fig.7-3)



(1) NOTE: Make sure that the rear wire harness Pigtail is routed out through the rear taillight access hole of the panel.

(d) Using a 10mm socket and the original D-Ring bolt (Reference Step 3. j.), install the lower hardware assembly over the panel onto the original D-Ring location. (Fig.7-4)

8. Reassemble Rear Cabin Interior Components

(a) Referencing Step 3. k. - n., reassemble the rear inner quarter panel, making sure that all fasteners, clips, etc, are securely fastened.

(1) The front portion of the rear inner quarter panel will need to hook into the inside of the rear cargo passenger side inner panel

(2) NOTE: Make sure that the rear wire harness Pigtail is routed out through the rear taillight access hole of the panel.



(b) Referencing Step 3. f. - i., reassemble the rear seat panel & two D-Rings, making sure that all fasteners, clips, etc, are securely fastened.



(1) Torque bolts to 31 lbf·ft (42 N·m)

(c) Referencing Step 3. d, reassemble the rear passenger side storage compartment.

(d) Referencing Step 3. c, reassemble the rear cargo entry scuff plate.

(e) Referencing Step 3. b, reassemble the rear Cargo Floor panel & floor mat (if equipped).

(f) Referencing Step 3. a, reassemble the rear Tonneau Cover.

(g) Referencing Step 3. e, reassemble the rear bench seat.

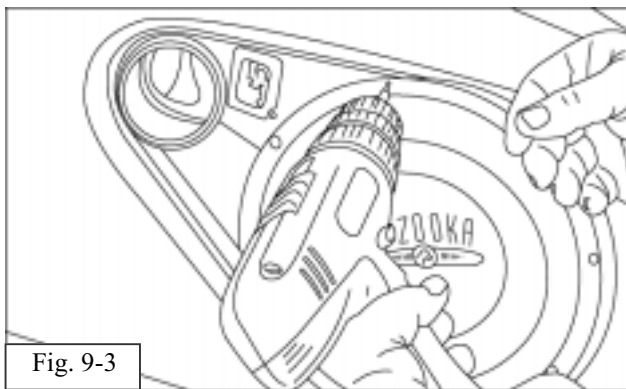
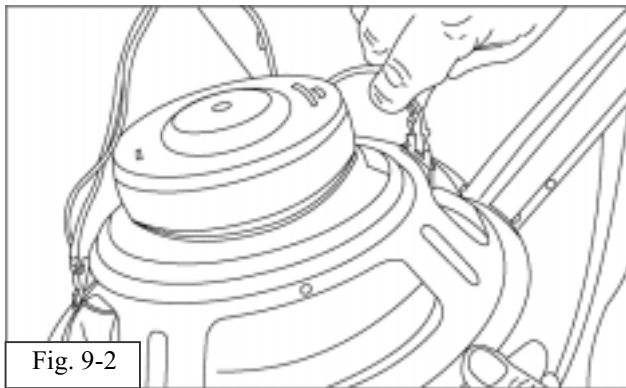
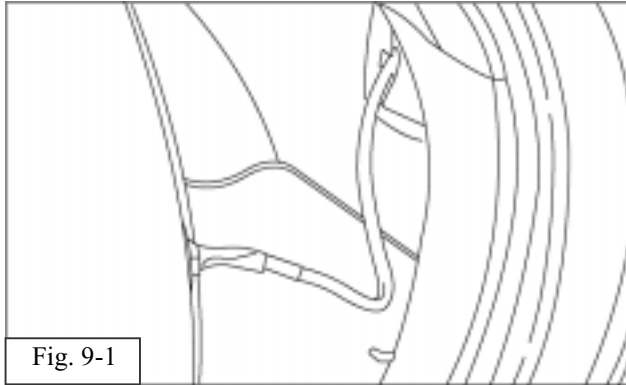

9. Install VSE Subwoofer

- (a) With the pigtail exiting the inner quarter panels tallight access hole, connect the pigtail to the VSE Subwoofer. (Fig.9-1)
- (b) Align the lower mounting stud through the enclosures lower hole, followed by the upper mounting stud.
 - (1) Install the lower mounting assemblies flat washer & locknut onto the lower mounting stud, **SECURELY** tighten using 10mm socket.
- (c) Install the upper mounting assemblies flat washer (with EVA gasket facing quarter panel) & lock nut onto the upper mounting stud, & **SECURELY** tighten using a 13mm ratcheting box end wrench.
- (d) Reinstall 10" driver into enclosure, by connecting the 4 speaker connectors to the driver (any sequence is acceptable). (Fig.9-2)
 - (1) Once connectors have been connected, align the holes of the driver with the holes of the enclosure, and fasten with the supplied 8 Philips head screws. (Fig.9-3)
- (e) Adjust the Gain Control knob to the factory suggested position (indicated by the setting dot). (Fig.9-4)
- (f) NOTE: Only reinstall front grille after completing Step 13 *Test & Set Up Procedures*

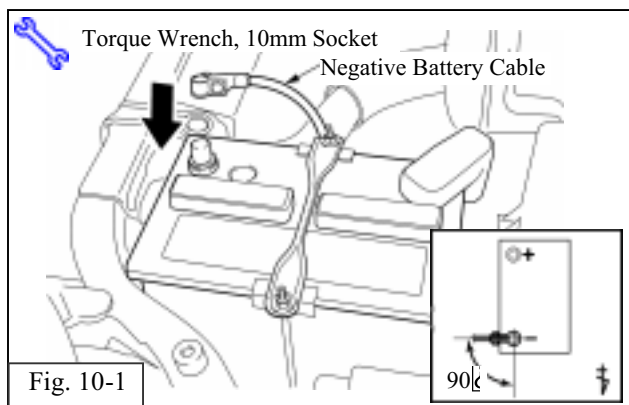

10. In Process Functional Test.

- (a) Reconnect the vehicle's negative battery cable. (Fig. 10-1)
 - (1) Position the negative terminal at an angle of 90° to the battery as shown.
 - (2) Tighten the nut with 4.1 N-m (36 lbf-in) of torque.
 - (3) Be careful not to touch the positive battery terminal.
- (b) Referencing Step 4. d., reassemble the Radio by connecting: 1) T-Harness into the back of the Radio 2) the Satellite harness (if equipped) and 3) the radio antenna cable.
 - (1) Carefully insert Radio back into center IP opening, by aligning mounting holes to the radio bracket. Be sure the wire harness is not pinched.
 - (2) Securely fasten (hand tighten) the four (4) mounting fasteners using the 10mm socket and #2 Philips Screwdriver. **DO NOT OVER TIGHTEN**
- (c) Turn ignition key to "ACC" position.
- (d) Press the power button on the receiver/player head unit. Verify the backlighting illuminates.
- (e) Verify that the green led on the VSE is illuminated, and that sound is coming out of the driver.

NOTE: If the green light on the VSE unit is illuminated, and there is no sound coming from the driver then one (or more) of the four (4) speaker wires are disconnected.

NOTE: If the green light on the VSE unit is NOT illuminated then the wire harness is not properly connected to either the radio/amplifier, or is not properly grounded.

11. Reassemble Front Cabin Interior Components

- (a) Referencing Step 4. g - f., reassemble all panels into their original locations, making sure that all clips are securely fastened.
- (b) Referencing Step 4. e., reassemble glove compartment, strut & lower glove box panel to its original location, making sure that all clips are securely fastened.
- (c) Referencing Step 4. c., carefully reconnect the vehicle harness back onto the center IP.
 - (1) Insert the center IP back onto the dash assembly by carefully inserting the top alignment tabs of the center IP into the dash assembly
 - (2) Once tabs are secured, then apply pressure to the perimeter of the center IP until it is flush with the dash assembly.
- (d) Referencing Step 4. b., carefully reconnect the cigarette lighter harness back onto the shift surround console
 - (1) Insert the shift surround console back onto the dash assembly by carefully aligning the alignment tabs.
 - (2) Once tabs are secured, then apply pressure to the perimeter of the shift surround console until it is flush with the dash assembly.
- (e) Referencing Step 4. a., screw the OE Shift Knob Clockwise until OE Shift Knob is securely tightened.

12. Resetting Vehicle Components

- (a) Reset the power windows.
 - (1) Turn ignition key to ON position.
 - (2) Push down the power window switches of each door, and lower the windows halfway.
 - (3) Pull up the switches until the windows close and hold switches up for a further one (1) second (minimum.)
- (b) Reset the power moon roof.
 - (1) Push and hold moon roof switch to close side until moon roof closes. Hold for a further two (2) seconds.
- (c) Reset the tailgate door.
 - (1) Push door lock control switch to the  side.
 - (2) Pull up tailgate door handle

13. Test and Set Up Procedures

- (a) If system is installed correctly, the VSE Subwoofer will power up when the vehicle  ignition is turned on. (This can be confirmed by the lighting of the POWER L.E.D. on the Gain Control module of the unit.) (Fig.9-5)
- (b) Using the tone controls on the radio, adjust the balance left and right, to verify that VSE Subwoofer produces sound on both sides, and that the sound is loudest when the balance is set to the center.
- (c) Tune to a radio station or CD, and adjust volume to a comfortable listening level. (If the sound is distorted, adjust the gain control knob counter-clockwise (-) until the VSE Subwoofer produces clean sound. If the unit cannot be heard, adjust the gain control

clockwise (+) until sufficient output is achieved.)

(d) Carefully reinstall grille.

14. Clean Up

(a) Clean up and remove any trash.

(b) If required, wipe down all applicable interior surfaces with 3M™ Prep Solvent-70, to remove fingerprints, etc

(1) When cleaning with 3M™ Prep Solvent-70:

(2) Always use a clean (lint free, scratch resistant) soft cloth (or wipe), and clean a small area at a time (~ 3 ft. x 3 ft. max.).

(3) **Shake Well.**

(4) Apply 3M™ Prep Solvent-70 to cloth or wipe. Do not spray cleaning solutions directly to **any** vehicle surfaces.

(5) Clean surface thoroughly and wipe dry immediately with a new clean cloth. Do not allow cleaner to air dry.

(c) Place Service Care Card in glove compartment

(d) Hang Product Feature Placard onto the rearview mirror.

<u>Condition:</u>	<u>Check For:</u>
<p><u>Accessory Function Checks</u></p> <ul style="list-style-type: none"><input type="checkbox"/> Turn on Radio<input type="checkbox"/> Verify CD & Satellite Tuner (if equipped) <input type="checkbox"/> Antenna is functioning<input type="checkbox"/> VSE Subwoofer operation	<p>Radio display turns on & sound is heard</p> <p>CD player functions & Satellite Tuner stations are playing (if equipped)</p> <p>Reception of AM/FM stations</p> <p>VSE Subwoofer <input type="checkbox"/> Listen to VSE Subwoofer to make sure it is functioning properly or by feeling the VSE Subwoofer for vibration. Be sure the Phase Switch is in the <input type="checkbox"/> UP <input type="checkbox"/> position.</p>
<p><u>Vehicle Function Checks</u></p> <ul style="list-style-type: none"><input type="checkbox"/> Hazard switch.<input type="checkbox"/> Passenger's seat belt reminder light. <input type="checkbox"/> Rear passenger seat back. <input type="checkbox"/> SRS warning light. <input type="checkbox"/> HVAC. <input type="checkbox"/> SSP function. <input type="checkbox"/> Lighter socket.	<p>Proper operation of the hazard switch.</p> <p>Proper operation of the passenger's seat belt reminder light</p> <p>Seat in upright position and seat back lock mechanism secured.</p> <p>SRS warning light illuminates for approximately 6 seconds with the ignition ON, and then goes out.</p> <p>Proper operation of the air conditioning system.</p> <p>Verify the radio SSP function is set to "tC" by pressing the "SSP" button on the head unit for 5 seconds. (If not, press the volume control and set to "tC".)</p> <p>Proper operation of lighter socket.</p>

Condition:

No sound from VSE Subwoofer, however factory speakers still play

Distorted Sound

Low Sound

Rattling Noises

Check For:

1. Is the green L.E.D. lit on the VSE Subwoofer? If not, check for 12 volts on pins of the VSE Subwoofer with the ignition on. If either pin doesn't indicate 12 volts, check T-Harness connectors behind the radio.
2. Is the 14-pin Molex connector securely connected to the VSE Subwoofer?
3. Is the ground ring securely fastened to the rear anchorage bolt?

1. Close the back hatch of the vehicle
2. Adjust the radio to a comfortable listening level, and then turn the [gain control] knob on the VSE Subwoofer counter-clockwise until the sound becomes clean.

1. Close the back hatch of the vehicle
2. Adjust the radio to a comfortable listening level, and then turn the [gain control] knob on the VSE Subwoofer clockwise until the sound becomes audible. Do not adjust the level too high, as this will result in distorted sound.

Rattling will be evident in some panels at extreme volume conditions, but make sure you have performed the following to minimize noise:

1. Securely tightened Mounting Hardware so VSE Subwoofer does not move.

Condition:

- Dimming Radio Lights

- Radio does not come on

- No Sound at all

- VSE Subwoofer produces sound on the right or the left, but not both.

Check For:

Dimming Radio Lights could occur when the VSE Subwoofer is played at high volumes.

Check to ensure that the main connector, antenna connector, and auxiliary connector have been correctly plugged back in.

1. Is the fuse under the hood still operational?
2. Is the battery ground reconnected?
3. Is the radio connector securely seated?

Check T-Harness connections at the back of the radio. All connectors must be securely fastened to the correct wiring for both channels to produce audio output.

WIRING CONNECTOR SCHEMATICS:		
		
Harness Split	Radio Connector	Subwoofer Connector
Harness Split Connector		
Pin No.	Wire Color	Function
1	Red	12 Volt Battery Connection (B+)
2	White/Black	Left Front Speaker (-)
3	Gray/Black	Right Front Speaker (-)
4	Blue/White	Remote Turn-On/Ignition (Switched+)
5	White	Left Front Speaker (+)
6	Gray	Right Front Speaker (+)
Subwoofer Connector		
Pin No.	Wire Color	Function
1	Black	Chassis Ground
2	N/A	N/A
3	N/A	N/A
4	N/A	N/A
5	White	Left Front Speaker (+)
6	Grey	Right Front Speaker (+)
7	N/A	N/A
8	Red	12 Volt Battery Connection (B+)
9	Blue/White	Remote Turn-On/Ignition (Switched+)
10	N/A	N/A
11	N/A	N/A
12	White/Black	Left Front Speaker (-)
13	Grey/Black	Right Front Speaker (-)
14	N/A	N/A
Radio Connector (R4 GRAY)		
Pin No.	Wire Color	Function
1		Right Front Speaker (+)
2		Left Front Speaker (+)
3	NO CONNECTION	NO CONNECTION
4	NO CONNECTION	NO CONNECTION
5		12 Volt Ignition Switched (B+)
6		12 Volt Battery Connection (B+)
7		Right Front Speaker (-)
8		Left Front Speaker (-)
9		Chassis Ground (B-)
10		Power Antenna Control (+)
11		Power Antenna Control (-)
12		Dimmer / Illumination Control (B+ variable)