

Part Number: PT546-21050

NOTE: Part number of this accessory may not be the same as the part number shown.

Kit Contents

Item #	Quantity Reqd.	Description
1	1	Receiver Assembly, Radio
2	1	Ground Cable
3	1	Receiver Cable
4	2	L-Bracket
5	2	Base Bracket
6	1	Template (to locate brackets)
7	1	Butyl Cushions
8	1	Antenna

Hardware Bag Contents-1

Item #	Quantity Reqd.	Description
1	1	Cushion Tape
2	7	Lock Tie A

Hardware Bag Contents-2

Item #	Quantity Reqd.	Description
1	4	Nut (M6)
2	4	Screw (M5 x 6)

Hardware Bag Contents-3

Item #	Quantity Reqd.	Description
1	1	Template (to locate antenna)
2	6	Lock Tie B
3	8	Urethane Tape (Black)
4	2	Cushion Tape (Gray)

Additional Items Required For Installation

Item #	Quantity Reqd.	Description
1	1	Receiver Cover  PT903-52040
2		
3		

Conflicts

--

Recommended Tools

Personal & Vehicle Protection	Notes
Safety Goggles	
Seat Cover	
Floor Protectors	
Protective Tape	Masking Tape

Special Tools	Notes
Scan Tool	
Installation Tools	Notes
Ratchet	
Extension	
Sockets	10 mm (deep), 12 mm, 14 mm
Screwdriver	Philips, #2
Nylon Panel Removal Tool	e.g. Panel Pry Tool #1 Toyota SST # 00002-06001-01
Utility Knife	
Torque Wrench	
Side Cutter	
Hexagon Wrench	2.5 mm
Special Chemicals	Notes
Cleaner	3M™ Prep Solvent-70

General Applicability

--

Recommended Sequence of Application





Item #	Accessory
1	Radio
2	Satellite Radio
3	Mudguards

*Mandatory

Vehicle Service Parts (may be required for reassembly)

Item #	Quantity Reqd.	Description
1		
2		
3		

Legend

	STOP: Damage to the vehicle may occur. Do not proceed until process has been complied with.
	OPERATOR SAFETY: Use caution to avoid risk of injury.
	CAUTION: A process that must be carefully observed in order to reduce the risk of damage to the accessory/vehicle and to ensure a quality installation.
	TOOLS & EQUIPMENT: Used in Figures calls out the specific tools and equipment recommended for this process.

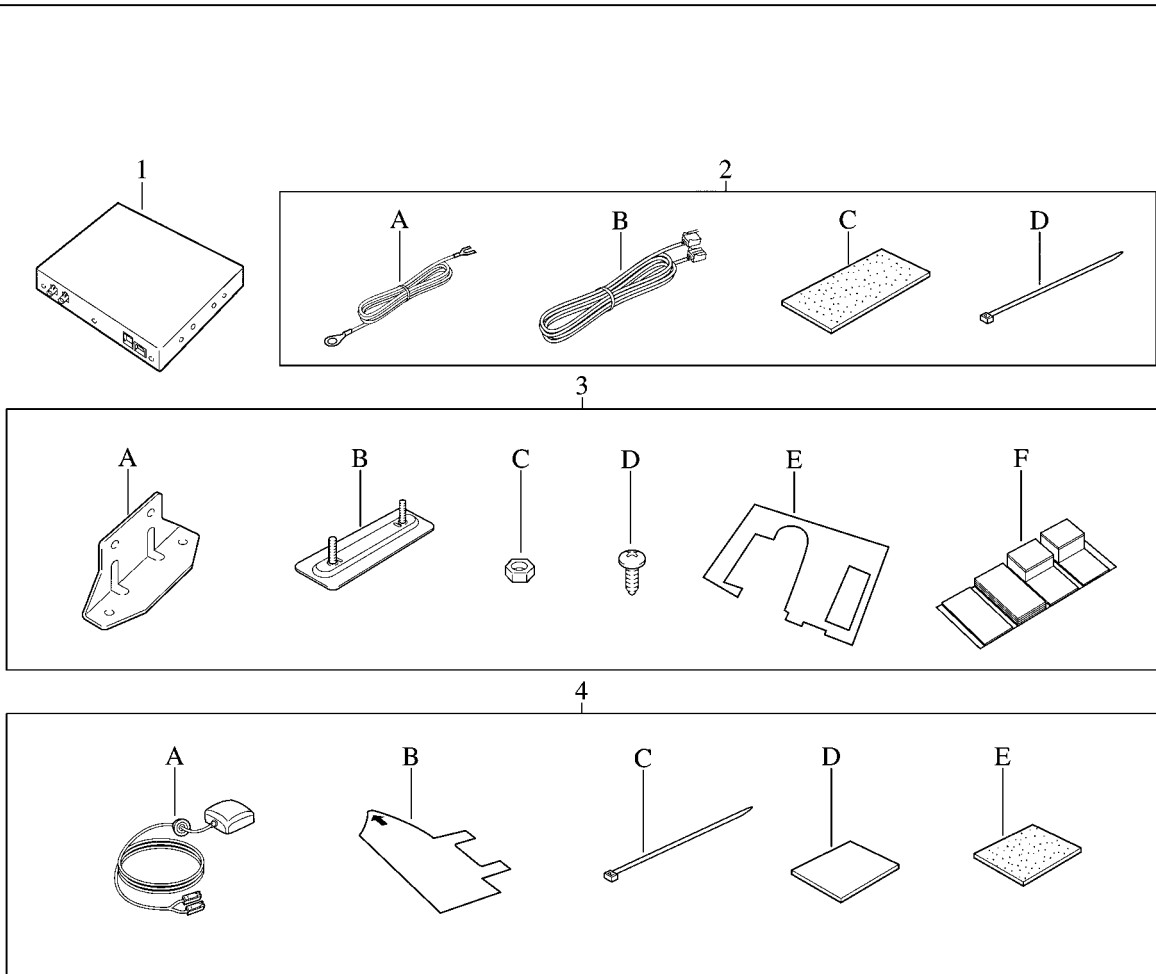

Item #		Parts Name	Qty
1		RECEIVER ASSY, RADIO	1
2	A	GROUND CABLE	1
	B	RECEIVER CABLE	1
	C	CUSHION TAPE	1
	D	LOCK TIE A	7
3	A	L- BRACKET	2
	B	BASE BRACKET	2
	C	NUT (M6)	4
	D	SCREW (M5 x 6)	4
	E	TEMPLATE (to locate brackets)	1
	F	BUTYL CUSHIONS	1
4	A	ANTENNA	1
	B	TEMPLATE (to locate antenna)	1
	C	LOCK TIE B	6
	D	URETHANE TAPE	8
	E	CUSHION TAPE (to fix antenna cable)	2

Care must be taken when installing this accessory to ensure damage does not occur to the vehicle. The installation of this accessory should follow approved guidelines to ensure a quality installation.

These guidelines can be found in the "Accessory Installation Practices" document.

This document covers such items as:-

- Vehicle Protection (use of covers and blankets, cleaning chemicals, etc.).
- Safety (eye protection, rechecking torque procedure, etc.).
- Vehicle Disassembly/Reassembly (panel removal, part storage, etc.).
- Electrical Component Disassembly/Reassembly (battery disconnection, connector removal, etc.).

Please see your Toyota dealer for a copy of this document.

1. Vehicle Disassembly.

- (a) Remove the negative battery cable.
(Fig. 1-1)

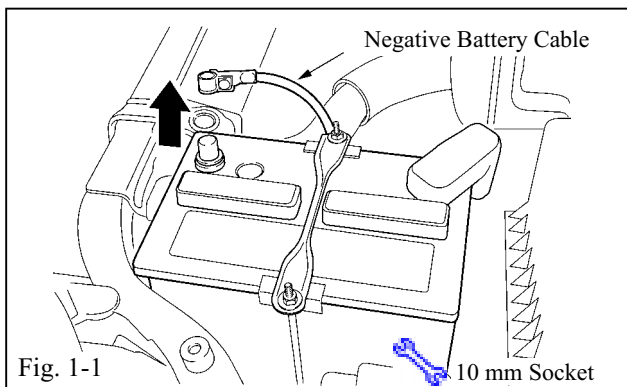

- (1) Protect fender before starting.



- (2) For vehicles equipped with automatic transmission, place the shifter in the N (neutral) position and set the parking brake prior to disconnecting the battery.



- (3) Do not touch the positive terminal with any tool when removing cable.

- (b) Remove the rear bumper cover.

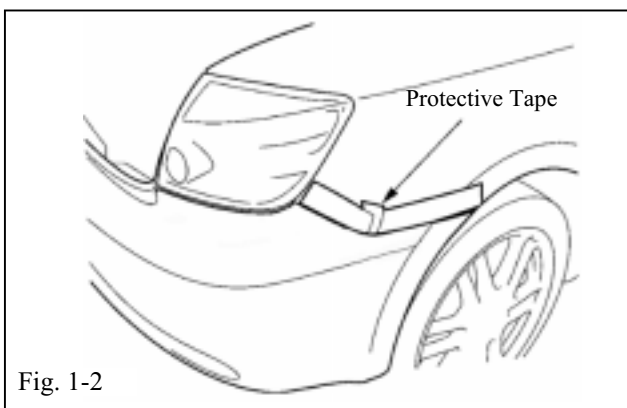

- (1) Clean the vehicle fender surface prior to applying protective tape.
- (2) Apply the protective tape to fender (on both sides.) (Fig. 1-2)

- (3) Remove the clips and bolts on the driver and passenger side bumper ends.
(Fig. 1-3)

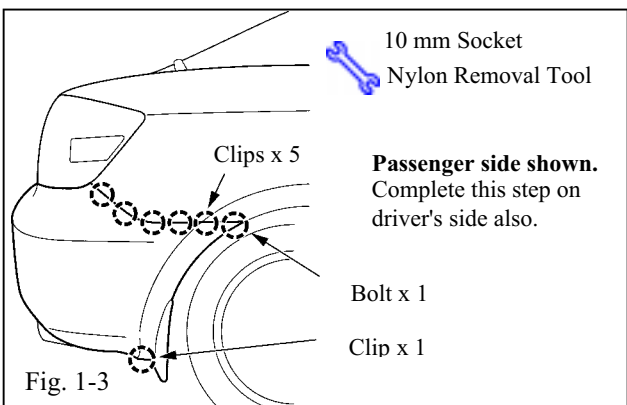

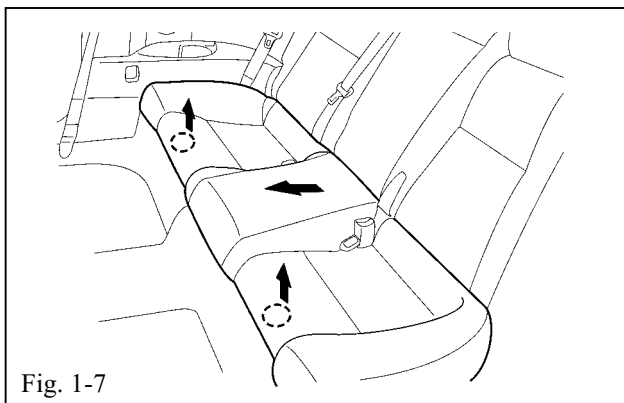
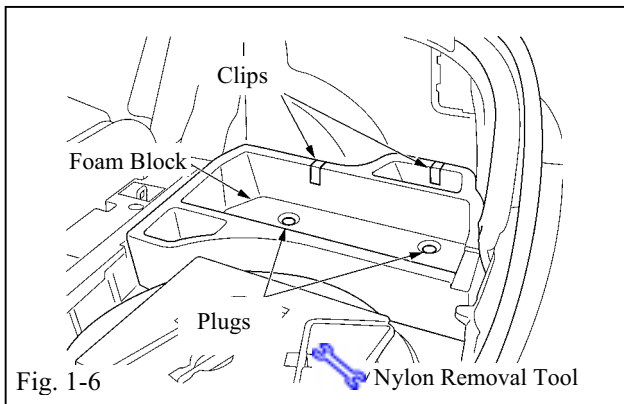
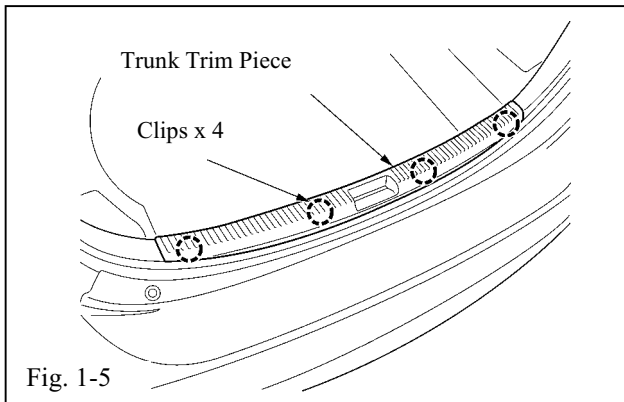
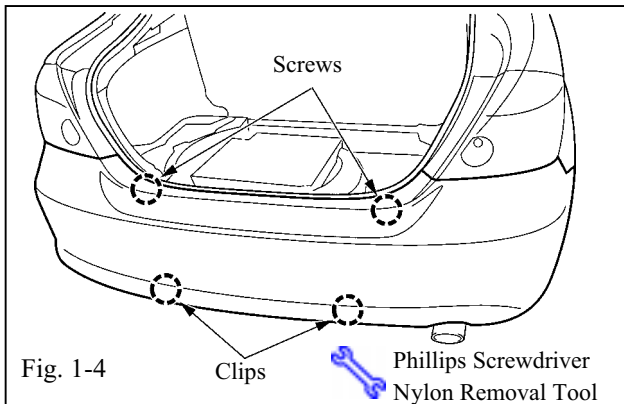

(4) Remove 2 screws from top of the bumper and 2 clips from the bottom. (Fig. 1-4)

(5) Pull gently on the sides of the bumper cover to release the clips.

(6) Remove the cover by pulling straight back.

(c) Remove the trunk accessories.

(1) Remove the trunk shelf.

(2) Remove the Deck Board Sub-assy (trunk mat)

(d) Remove the Back Door Scuff Plate piece.

(1) Pull trim piece straight up to remove. (Fig. 1-5)

(e) Remove the Deck Floor Box RH (foam block) on the passenger side of the trunk floor.

(1) Remove the plastic plugs and pull the box straight up. (Fig. 1-6)

(f) Remove the rear seat cushion. (Fig. 1-7)

(1) Pull upward on the front of the seat cushion to release, and then slide the seat cushion forward and upward.

NOTE: Be careful not to damage the seat, door and other vehicle parts when removing the seat cushion from the vehicle.

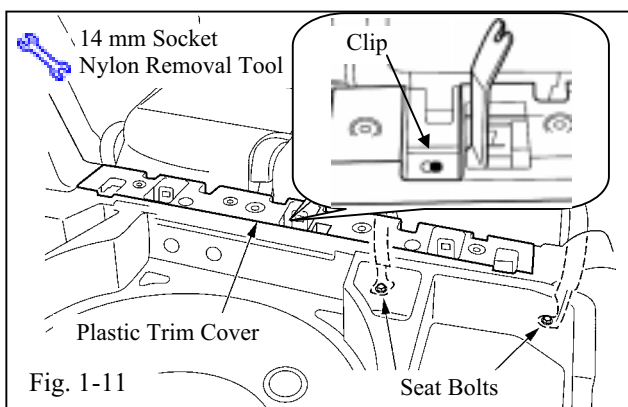
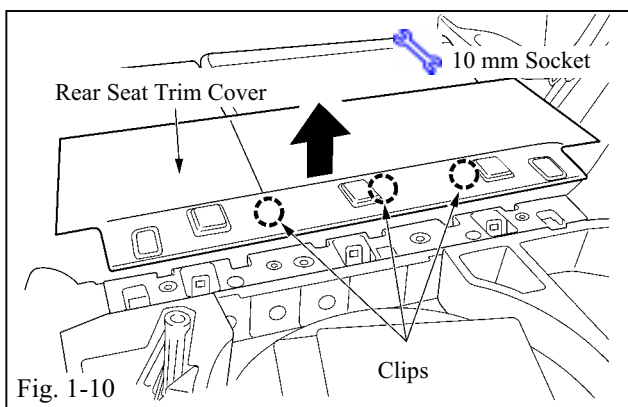
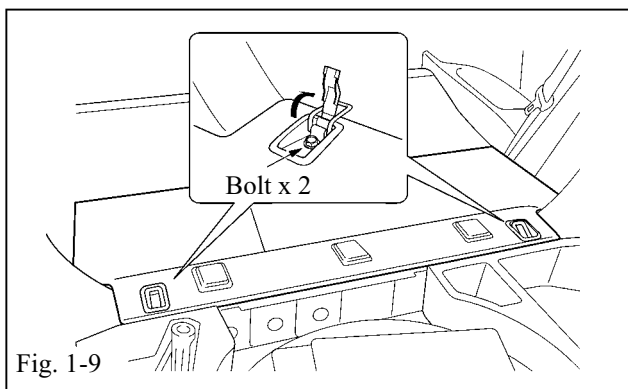
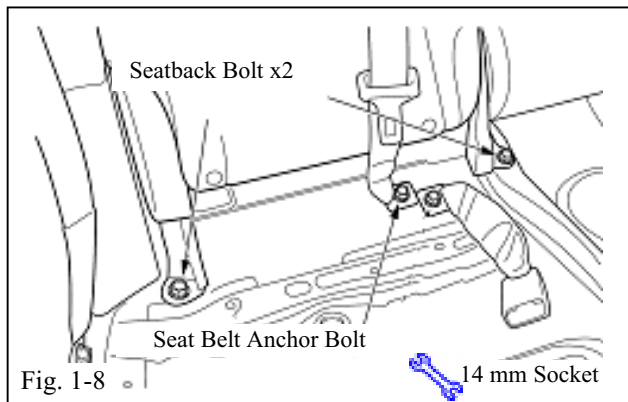

(g) Remove the rear passenger seat back.

(1) Unbolt the seat back bolts and the middle seat belt anchor bolt. (Fig. 1-8)

(2) Fold both the driver and passenger seat back forward.

(3) Unclip the plastic cover on both cargo tie down loops, remove the bolts and the tie down assemblies. (Fig. 1-9)

(4) Unclip the Rear Deck Board No. 1 (rear seat trim) cover and remove from vehicle. (Fig. 1-10)

(5) Unlock the clip by inserting removal tool as shown in Fig. 1-11.

(6) Remove the clip and pull straight up to remove the Rear Floor Board No. 1 (plastic trim cover over the rear cross beam.) (Fig. 1-11)

STOP **NOTE:** Be sure not to break the cover while removing.

(7) Remove the two (2) bolts that retain the rear passenger seat back. (Fig. 1-11)

(8) Remove the rear passenger seat back from the vehicle.

STOP **NOTE:** Be careful not to damage the seat, door and other vehicle parts when removing the seat cushion from the vehicle.

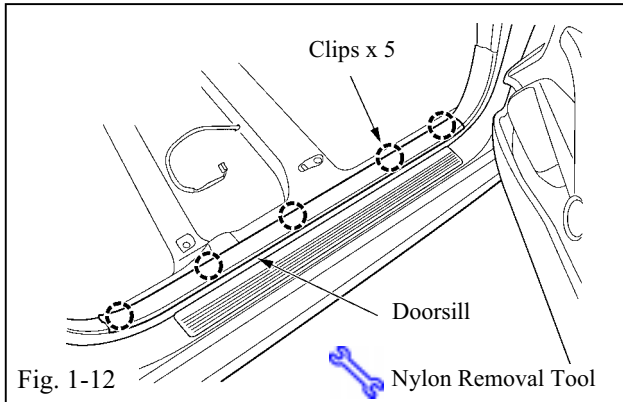

(h) Remove passenger side doorsill. (Fig. 1-12)

NOTE: If a clip remains on the vehicle, remove it and replace it back into the plastic doorsill cover.

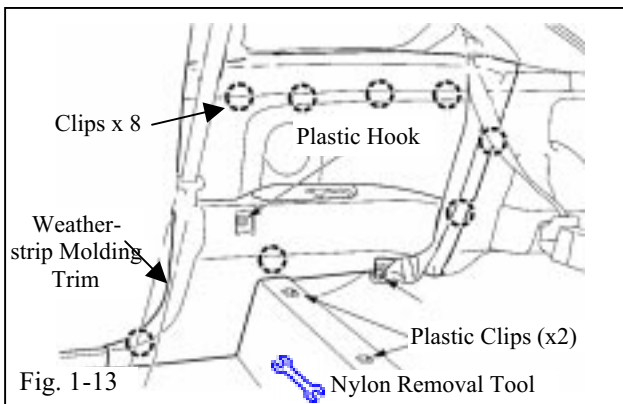

(i) Remove the rear passenger side trim.

- (1) Remove the plastic hook to remove the rear passenger side trim (Fig. 1-13)
- (2) Push on the button with a nylon removal tool and twist hook counter-clockwise by 90 deg.. (Fig. 1-14)
- (3) Pull hook straight out while pushing button. (Fig. 1-14)
- (4) Remove the two (2) plastic clips on the floor. (Fig. 1-13)
- (5) Partially remove the weather-strip molding trim.
- (6) Pry off the side trim panel to release the 8 clips and 3 claws (along upper edge.)

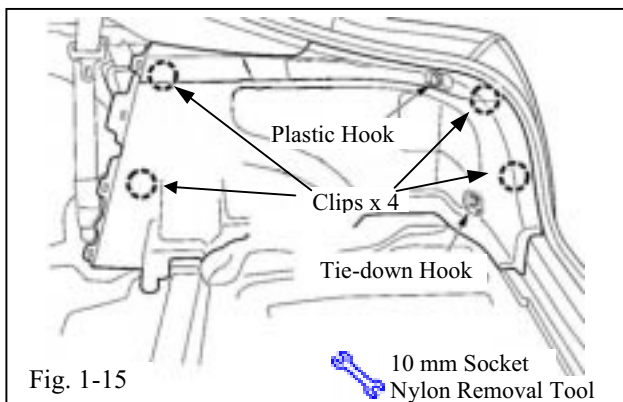
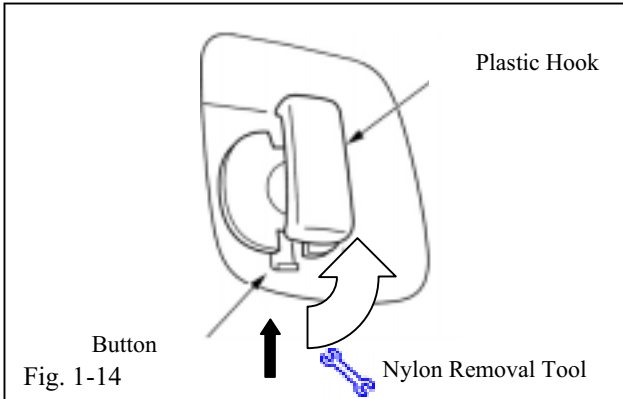

(j) Remove the rear passenger side trunk trim.

- (1) Remove tie-down hook. (Fig. 1-15)
Pry open plastic clip.
Remove bolt.
Pull out hook assembly.

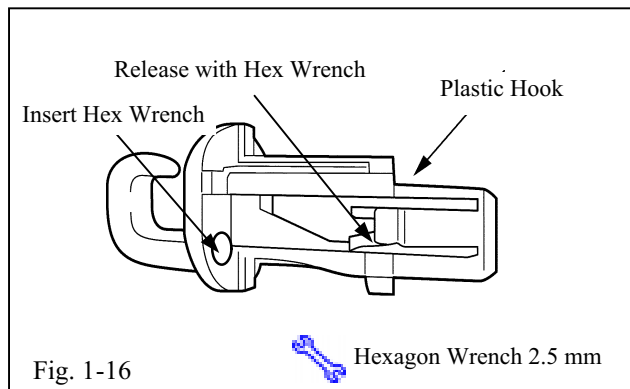

- (2) Remove the plastic hook. (Fig. 1-15)
Insert a 2.5 mm Hexagon Wrench through oval hole in hook to release the hook. (Fig. 1-16)
Pull out the plastic hook.

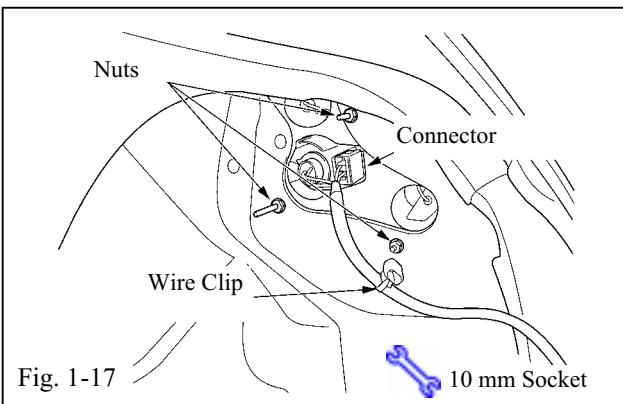

- (3) Pry panel off to release the 4 (four) clips and 3 claws (along upper edge). (Fig. 1-15)
- (k) Remove the passenger side tail lamp. (Fig. 1-17)
 - (1) Remove wire clip from tail lamp bolt.
 - (2) Remove the three (3) tail lamp nuts.
 - (3) Pull out the lamp connector.
 - (4) Pull tail lamp straight out to remove.

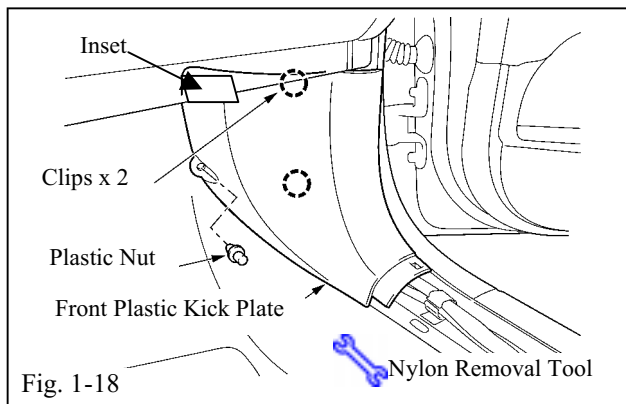

- (l) Remove front plastic kick plate. (Fig. 1-18)
 - (1) Remove the glove box underdash cover.
 - (2) Unscrew plastic nut by hand.
 - (3) Pry off cover.

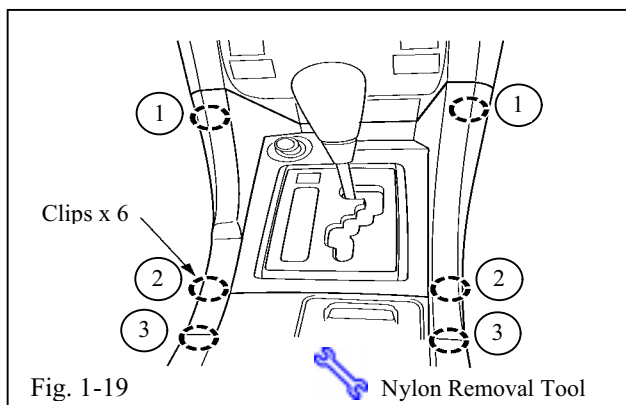

- (m) Remove the lower console panel. (Fig. 1-19)
 - (1) Confirm shifter is in neutral position.
 - (2) Remove the six (6) clips in order shown.
 - (3) Remove connector and clip for lighter.

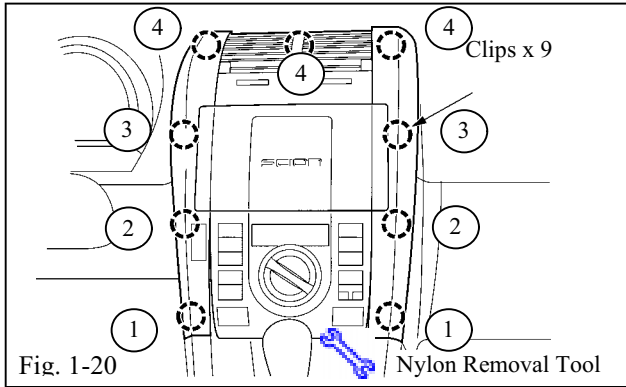

(n) Remove the upper console panel. (Fig. 1-20)

(1) Close the radio cover.



(2) Remove the nine (9) clips in order shown.

(3) Pull off connector for air conditioner.

2. Remove the Head Unit.

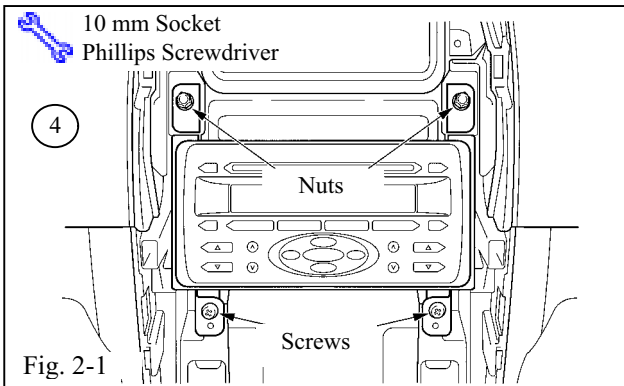

(a) Remove the two (2) nuts on top and the two (2) screws on the bottom. (Fig. 2-1)

(b) Pull head unit straight out.

(c) Disconnect the connectors.

3. Remove the Glove Box.

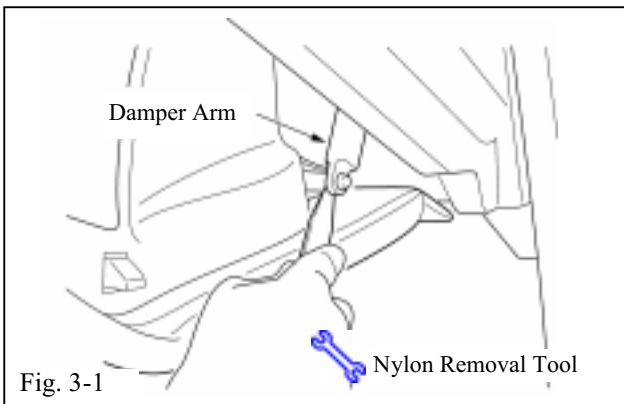

(a) Open the glove box.

(b) Disconnect the damper using a nylon removal tool. (Fig. 3-1)

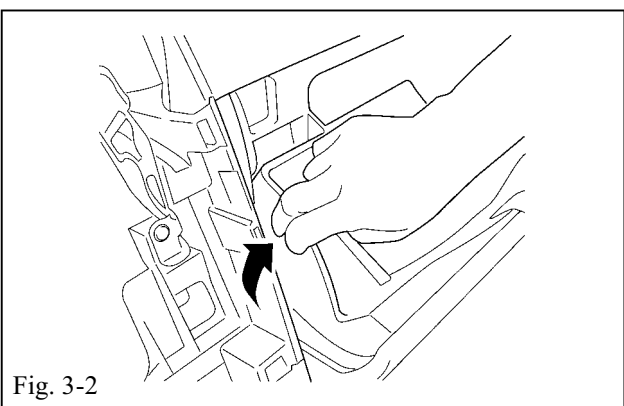

(c) Push both sides and pull off one by one. (Fig. 3-2)

(d) Pull the glove box straight out to release the bottom clips.

4. Remove Passenger Front Seat.

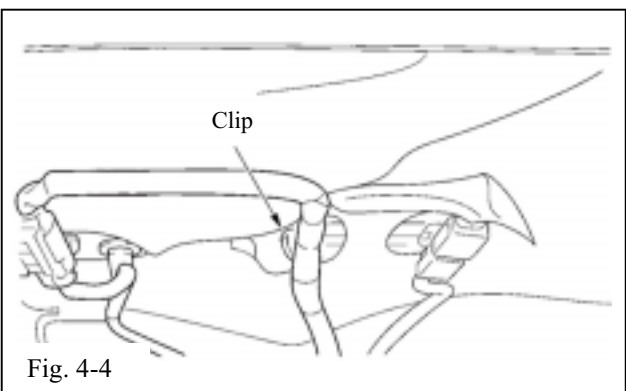
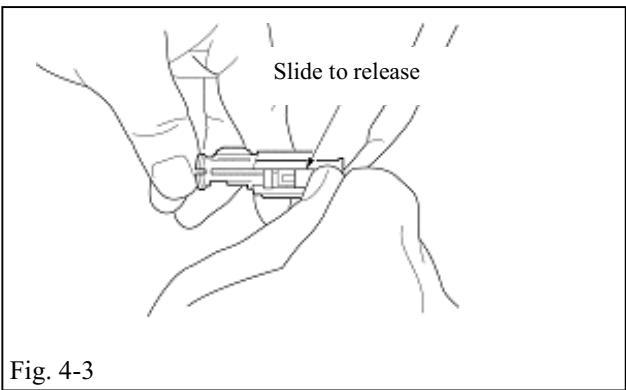
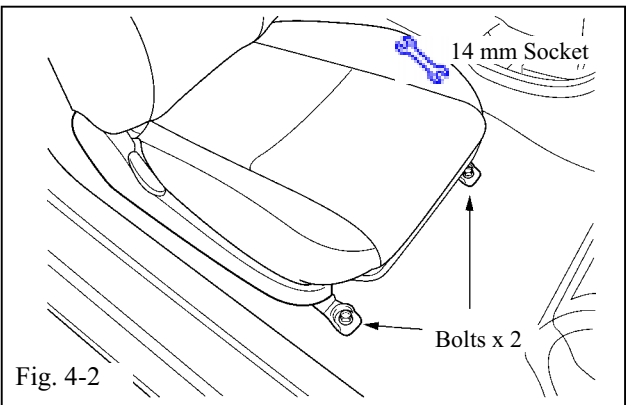
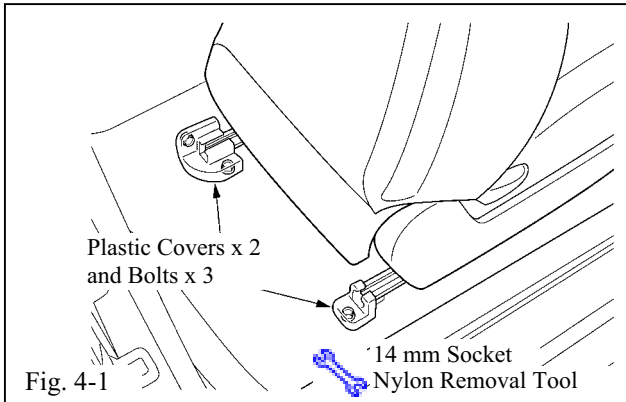

(a) Protect the center console area before removing seat.

(b) Slide the seat forward and remove the two (2) plastic covers on the seat rails. Remove the three (3) bolts under the plastic covers. (Fig. 4-1)

(c) Slide the seat backwards and remove the two (2) bolts that hold the front end of the seat rails. (Fig. 4-2)

(d) Tilt the seat up and disconnect the two (2) wire harnesses. The yellow connector is unlocked by sliding the white portion of the connector. (Fig. 4-3)

(e) Remove the clip shown. (Fig. 4-4)

(f) Place the seat in the rear seat area.



NOTE: Be careful not to damage the seat, scuff plate, door and other vehicle parts when moving the seat in the vehicle.

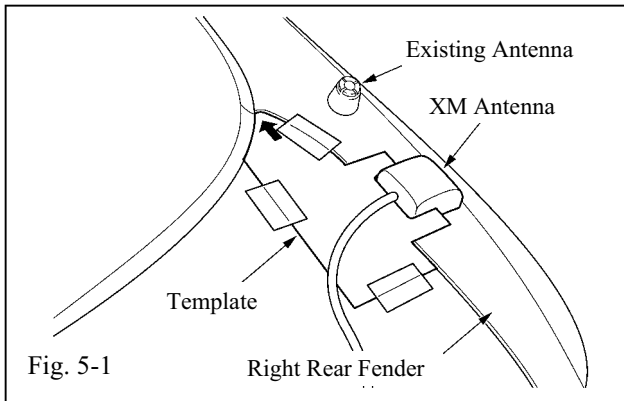

Fig. 5-1

5. Install the Antenna.

- (a) Close the rear hatch.
- (b) Clean the antenna mounting area with 3M™ Prep Solvent-70. (Fig. 5-1)
 - (1) When cleaning with 3M™ Prep Solvent-70, follow the manufacturer's directions. Do not allow cleaner to air dry.
- (c) Position and tape the antenna mounting template onto the right rear (passenger side) hatch as shown, secure with masking tape. (Fig. 5-1)
- (d) Remove the release paper from the back of the antenna, and then attach the antenna on the fender.
- (e) Remove and discard the mounting template.

6. Install the Antenna Cable.



NOTE: Clip all lock ties after tightening.

- (a) Temporarily reconnect the negative battery cable.
 - (1) Unlock the rear hatch door using driver side master unlock switch.
 - (2) Open the rear hatch
- (b) Disconnect the negative battery cable.
- (c) Clean all the tape mounting areas. (Figs 6-1 to 6-4)
- (d) Use black urethane tape (2 places) to secure the antenna cable so it doesn't rub or pinch when the trunk lid is closed. (Fig. 6-1)

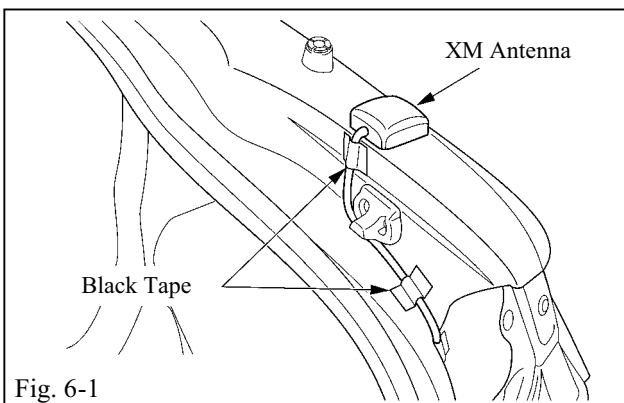
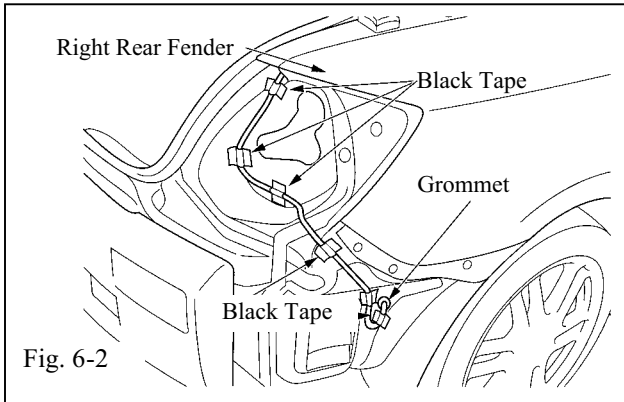
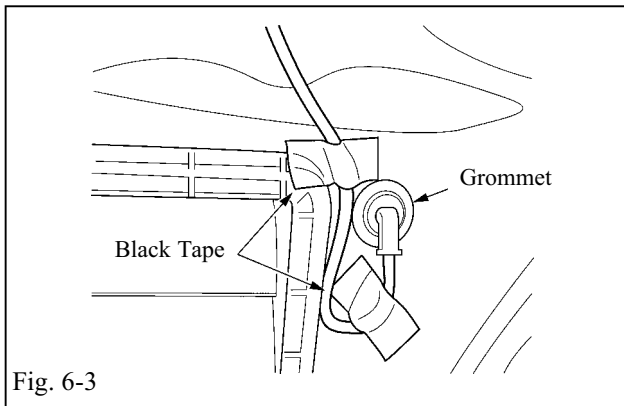

Fig. 6-1



(e) Use black urethane tape (4 places) to route the antenna cable on the exterior of the vehicle as shown. (Fig. 6-2)



(f) From the inside, push outward and remove the grommet plug, then route the antenna cable through the body hole. (Fig. 6-3)

(g) Install the antenna grommet (attached to cable) into the body hole. Secure the cable with black urethane tape (2 places) as shown. (Fig. 6-3)

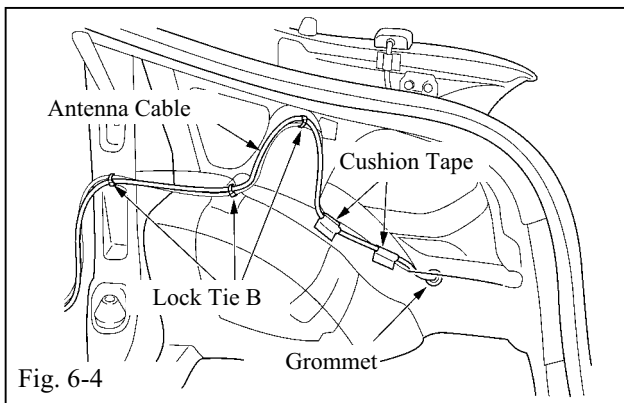

(h) Route the antenna cable inside the vehicle as shown. Secure with gray cushion tape (2 places) and three (3) lock tie B as shown. (Fig. 6-4)

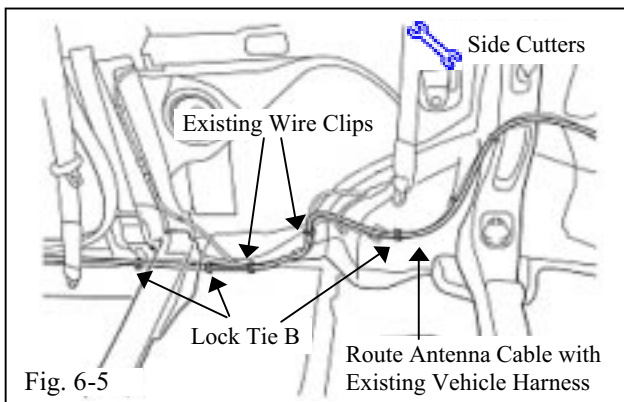

(i) Route the antenna cable under the front crossbeam, and along the passenger doorsill. Place cable into the existing clips as shown. (Fig. 6-5)

(j) Secure cable with three (3) lock ties (B) as shown. (Fig. 6-5)

7. Install and Route the Receiver and Ground Cable.

(a) Install and route the receiver cable from the center cluster along the front support bar, then down to the passenger side doorsill. Provide sufficient cable slack to connect to the audio head unit as shown. Adjust the slack of the cable to match slack of other cables. (Fig. 7-1)

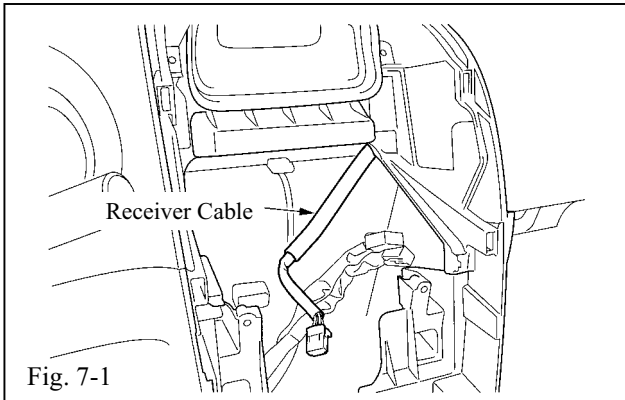

(b) Secure the tuner cable to the front support bar with three (3) lock ties (A). Be sure to place gray cushion tape over the (potentially sharp) welds on the support bar. (Fig. 7-2)

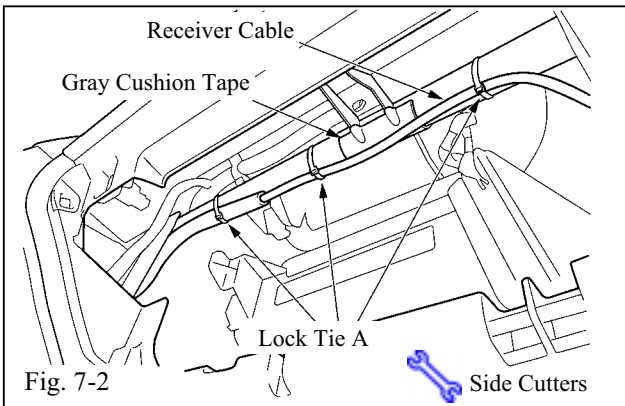

(c) Install the tuner ground cable as shown. Loosen the bolt and slide in the spade connector, then retighten the bolt. (Fig. 7-3)

(d) Route the receiver cable with the ground cable downward. Secure with lock tie A as shown. (Fig. 7-3)

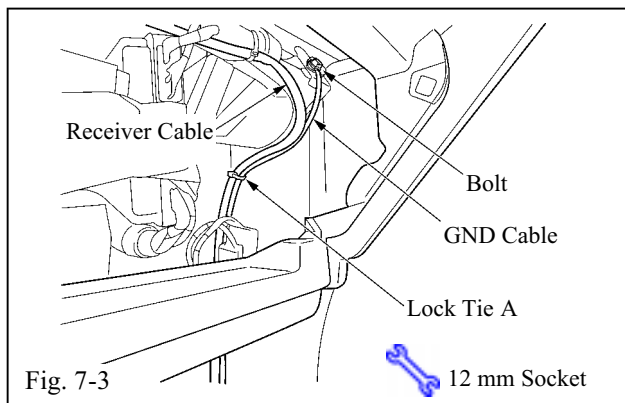

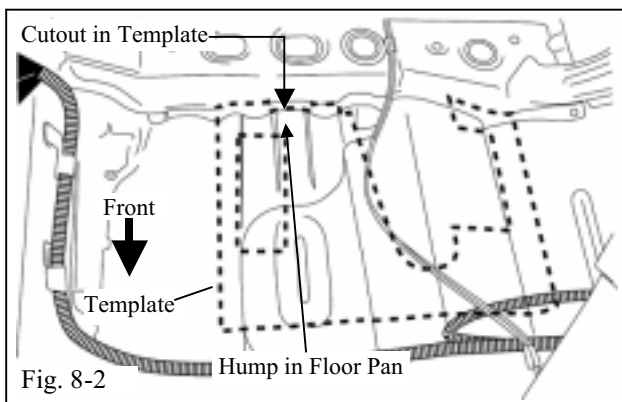
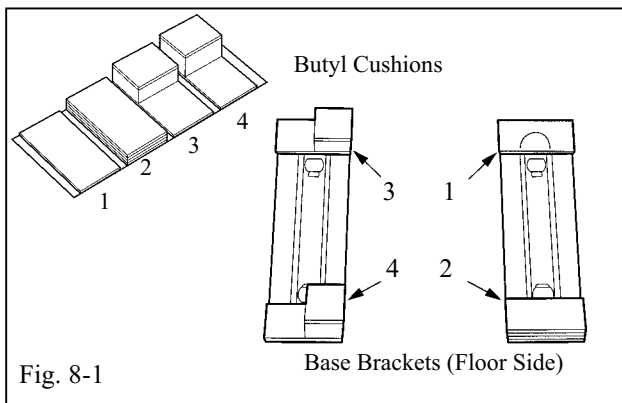
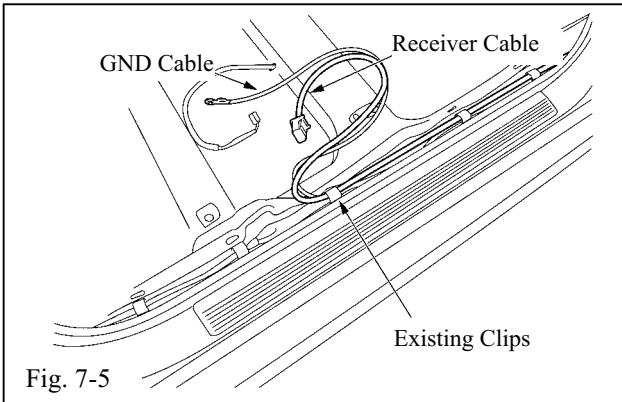
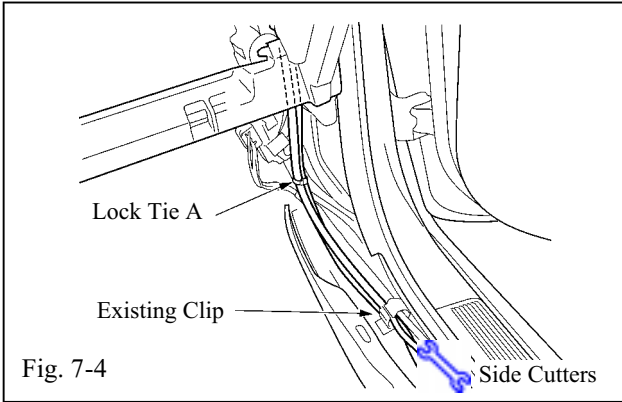

- (e) Route the receiver and ground cables through the existing wire clips along the doorsill. (Fig.s 7-4 and 7-5)
- (f) Secure with lock tie A as shown. (Fig. 7-4)

8. Install the Receiver.

- (a) Place the butyl cushions on the base brackets as shown. (Fig. 8-1)
- (b) Fold the carpeting back. Clean the base bracket mounting area.
- (c) Position the mounting template as shown. White side faces up. Line up rear of template with seat support cross member. Line up the cutout in the template with the hump in floor pan. Press down to form the template to the floor pan. (Fig. 8-2)

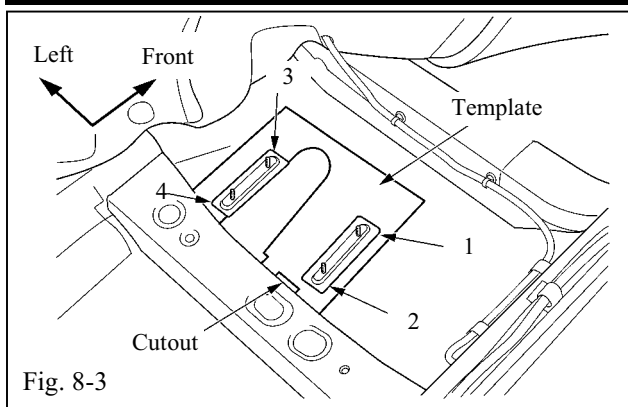

(d) Using the template as a guide, install the base brackets with butyl cushions to the floor pan. (Fig. 8-3)

(e) Remove and discard the template.

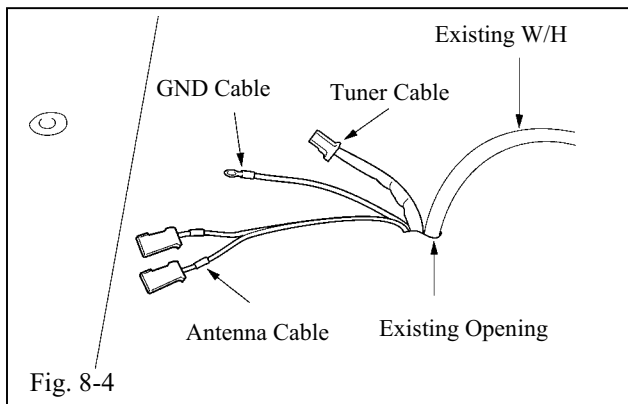

(f) Route the antenna cable, tuner cable and ground cable through the existing opening in the carpet. The tuner cable and ground cable should protrude approximately 120 mm (5 inch) from the carpet; the antenna cables should extend approximately 200 mm (8 inch.) (Fig. 8-4)

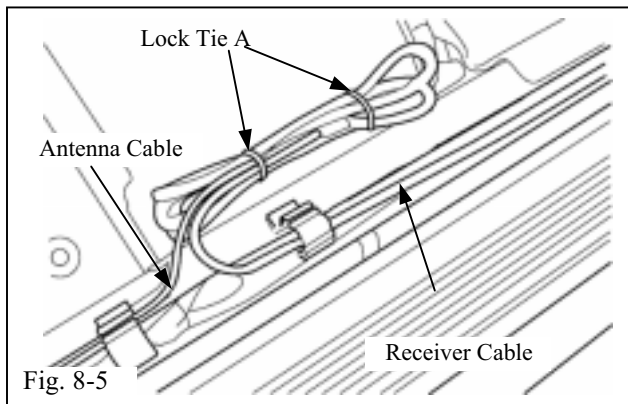

(g) Route the receiver cable and the antenna cable as shown in Fig. 8-5.

(h) Bundle excess receiver and ground cable lengths in area shown. Secure with two (2) lock ties (A). (Fig. 8-5)



(1) Make sure the cables do not interfere with inner of scuff plate.

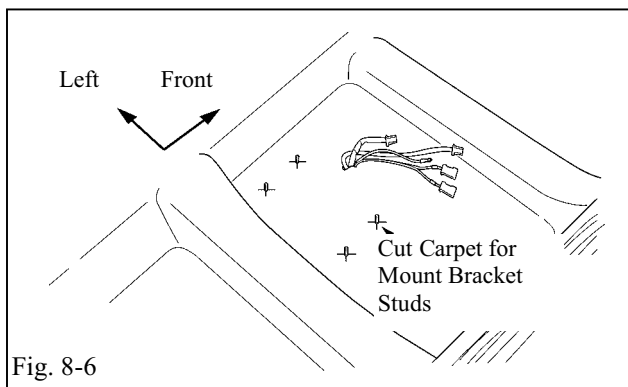

(i) Fold the carpet back down over the base brackets. Using a utility knife, cut four X-shaped openings in the carpet to expose the base bracket studs. (Fig. 8-6)

(j) Replace the carpet making sure to hook the carpet side to the existing 5 (five) clips.

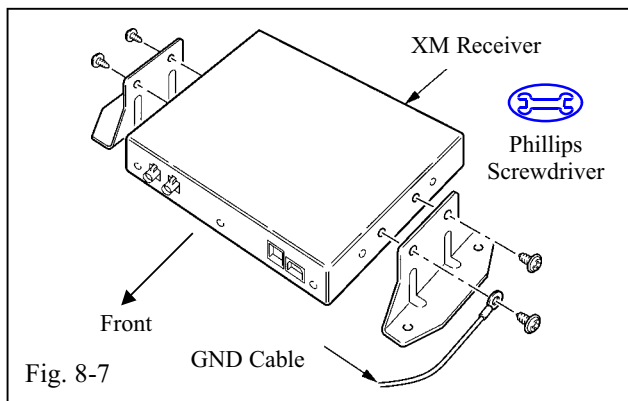

Fig. 8-7

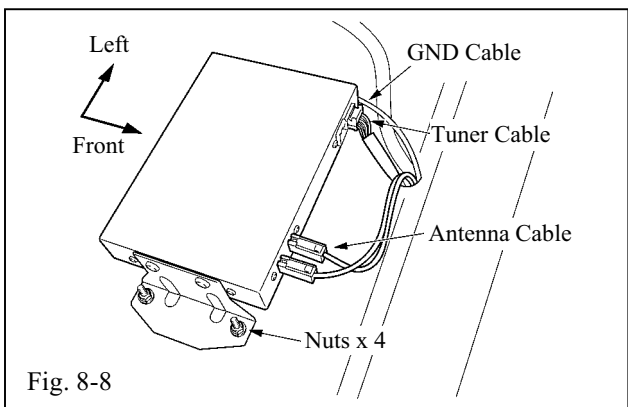

Fig. 8-8

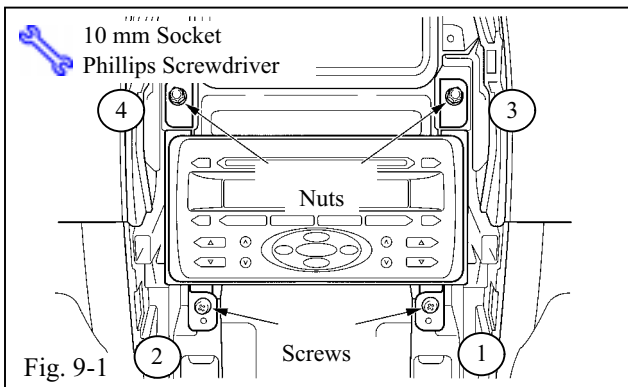

Fig. 9-1

(k) Install the L-brackets and ground cable onto the receiver. (Fig. 8-7)

(l) Place the receiver with L-brackets onto the studs so that the connectors face toward the front of the vehicle. Install the nuts onto the studs and tighten. (Fig. 8-8)

(m) Plug the tuner and antenna cables into the receiver.

(1) Connect the antenna cable connectors of the same color to the tuner.

9. Reinstall the Radio/Player Head Unit.

(a) Connect the satellite tuner cable and the connectors removed in Step 2. (c) into the rear of the head unit.



(b) Insert head unit into opening and re-install the two (2) screws and two (2) nuts in order shown. (Fig. 9-1)

10. In Process Functional Test.

(a) Temporarily reconnect battery negative cable.

(b) Turn ignition key to "ACC" position.

(c) Press the power button on the receiver/player head unit. Verify the backlighting illuminates.

(d) Press and release the "SAT" button on the head unit.

(1) Verify that a satellite channel is received, or a "NO SIGNAL" message appears on the display.

NOTE: If "ANTENNA" appears (flashing) on the display  then one or both of the antenna cables are disconnected from the satellite tuner.

NOTE: If the head unit will not tune or go into satellite mode -- then the tuner cable is disconnected from the satellite tuner.

- (e) Disconnect battery negative cable.

11. Installing Receiver Cover.

- (a) Remove the satellite receiver cover (P/N PT903-52040) from the poly bag.
- (b) Shape the cover so that it forms an open box shape with the Velcro™ facing down.

NOTE: Shipping and storage may have caused the shape to distort.

- (c) Peel the backing off the sewn-in Velcro™ strip inside the cover. (Fig. 11-1).
 - (1) Do not separate the Velcro™.
- (d) Clean the top of satellite receiver box with 3M™ Prep Solvent-70.
 - (1) When cleaning with 3M™ Prep Solvent-70, follow the manufacturer's directions. Do not allow cleaner to air dry.

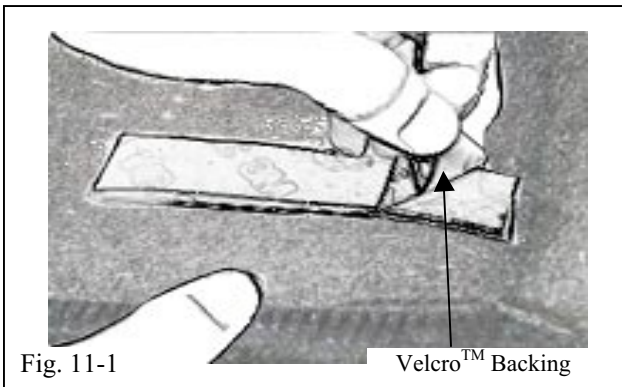

- (e) Align the rear edge of the cover with the rear edge of the satellite receiver. (Fig. 11-2).
- (f) Place the rear edge between the receiver and seat support cross member, such that the rear edge is on the floor pan. (Fig. 11-3)
- (g) Center cover to ensure satellite receiver mounting bolts are covered. Press Velcro™ to the floor carpet around the perimeter.
- (h) Press the sewn-in Velcro™ tab on the top underside of the cover firmly to the satellite receiver. (Fig. 11-3).

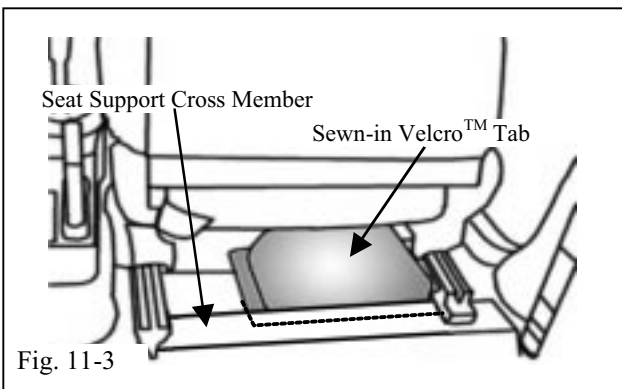
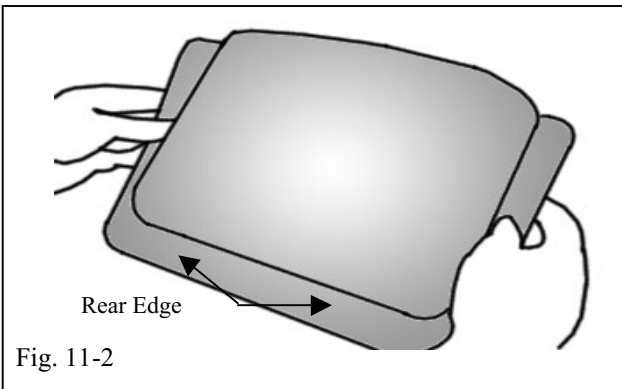

12. Complete the Reassembly of the Vehicle:

(a) Re-install the front seat

(1) Reinstall the five (5) bolts loosely, then tighten them.



(2) Tighten bolts to 40 N-m (30 lbf-ft)

(3) Reconnect any disconnected connectors.

(b) Reinstall glove box.

(c) Reinstall upper console panel.

(1) Reconnect any disconnected connectors.

(d) Reinstall lower console panel.

(1) Reconnect the lighter connector and clip.

(e) Reinstall kick plate and glove box underdash cover.



(1) Ensure that cover is located in the inset (Fig. 1-18).

(f) Reinstall doorsill.

(g) Reinstall rear tail lamp.

(1) Reconnect the lamp connector.

(h) Reinstall passenger side trunk trim and rear passenger side trim panels.

(i) Reinstall rear passenger seat back, seat back bolts (2), seat belt anchor bolt, plastic trim cover and rear seat trim cover.



(1) Tighten bolts to 42 N-m (31 lbf-ft)

(j) Reinstall rear seat cushion

(k) Reinstall foam block, trunk trim piece and trunk accessories.

(l) Reinstall bumper cover.

(m) Verify the panels fit together properly with no uneven gaps between them.

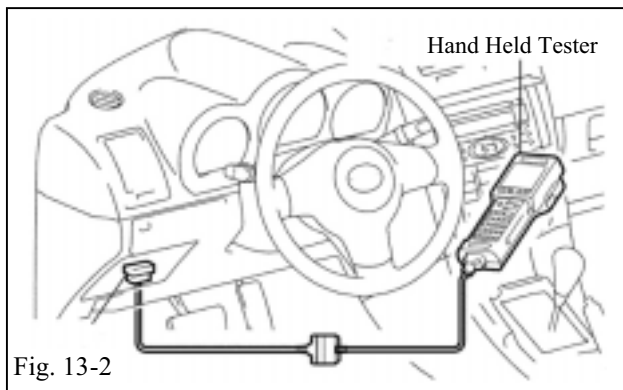
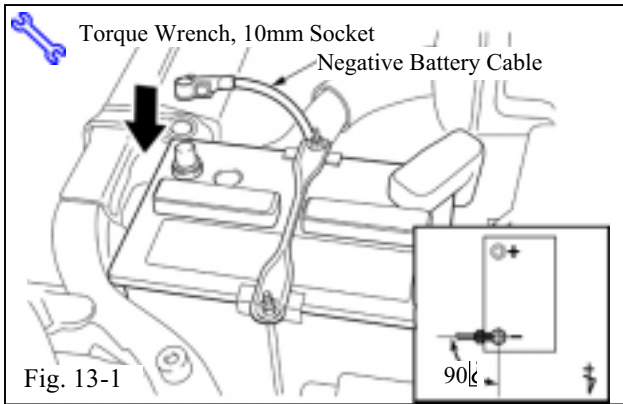

13. Reconnect Battery Cable.

- (a) Reconnect the vehicle's negative battery cable. (Fig. 13-1)
 - (1) Position the negative terminal at an angle of $\sim 90^\circ$ (+- 30) to the battery as shown.
 - (2) Tighten the nut with 4.1 N-m (36 lbf-in) of torque.
 - (3) Be careful not to touch the positive battery terminal.



- (b) Connect the scan tool connector to the vehicle's diagnostic connector in the lower dash area. (Fig. 13-2)
 - (1) Turn ignition switch to ON position.
 - (2) Check for Airbag ECU trouble codes \square if present then clear the DTCs.
 - (3) Refer to hand held scan tool tester operator's manual for further details.



NOTE: Check for the latest version of the software on Toyota Information System (TIS) before setting up the scan tool.



NOTE: Ensure the software is the latest version (Evaluation Version 11.0a. (R129 -- 05/24/04) or later.)



NOTE: Download the latest software from Toyota Information System (TIS).

- (c) Clean up and remove any trash.



- (d) Place the owner "xM Satellite Radio" brochure in the glove box.

14. For Accessory fitted after Pre Delivery Service Only.

- (a) Reset the power windows.
 - (1) Turn ignition key to ON position.
 - (2) Push down the power window switches of each door, and lower the windows halfway.
 - (3) Pull up the switches until the windows close and hold switches up for a further one (1) second (minimum.)
- (b) Reset the power moon roof.
 - (1) Push and hold moon roof switch to close side until moon roof closes. Hold for a further 2 seconds.
- (c) Reset the tailgate door.
 - (1) Push door lock control switch to the "unlock" side.
 - (2) Pull up tailgate door handle.

Checklist - these points **MUST** be checked to ensure a quality installation.

Check:

Look For:

Accessory Function Checks

- Satellite Radio Tuner.
- Receiver/player Assembly.

- *Verify the proper operation of the Satellite Radio Tuner.
- *Verify the proper operation of the Receiver/player Assembly
- *(Refer to the receiver assembly and radio owner's manuals.)

Vehicle Function Checks

- Hazard switch.
- Passenger's seat belt reminder light.
- Passenger front seat.
- Rear passenger seat back.
- SRS warning light.
- HVAC.
- SSP function.
- Lighter socket.
- Diagnostic Codes -- using Scan Tool.

- Proper operation of the hazard switch.
- Proper operation of the passenger's seat belt reminder light
- Removed seat is securely fastened.
- Seat in upright position and seat back lock mechanism secured.
- SRS warning light illuminates for approximately 6 seconds with the ignition ON, and then goes out.
- Proper operation of the air conditioning system.
- Verify the radio SSP function is set to "tC" by pressing the "SSP" button on the head unit for 5 seconds. (If not, press the volume control and set to "tC".)
- Proper operation of lighter socket.
- Confirm that no diagnostic trouble codes are present.