

Part Number: PT398-48110

NOTE: Part number of this accessory may not be the same as the part number shown.

Conflicts

Do not install into vehicles without RKE systems. Will not program with Techstream Lite.

Recommended Sequence of Application

Item #	Accessory	

Kit Contents

Item #	Quantity	Description
1	1	Wire Harness
2	1	Gateway ECU Mounting Bracket
3	1	RES ECU Mounting Bracket

Hardware Bag Contents

Item #	Quantity	Description
1	1	RES ECU
2	1	Gateway ECU
3	1	Foam Tape
4	25	Wire Ties
5	2	M6 Tapping Screws
6	2	M2 x 14 Screws
7	2	Splicing Connectors
8	1	Bolt Cover
9	1	Hood Switch
10	4	Window Warning Labels English / Spanish
11	4	Transmitter Labels English / Spanish
12	4	Key Tag English / Spanish
13	2	Warning Labels for Engine Compartment English / Spanish
14	1	Owner's Manual







Additional Items Required For Installation

Item #	Quantity	Description
1	1	Black Electrical Tape

Recommended Tools

Personal & Vehicle Protection	Notes
Safety Glasses	
Safety Gloves	(Optional)
Vehicle Protection	Blankets, Parts Boxes
Special Tools	Notes
Techstream	Do not use Techstream Lite
Installation Tools	Notes
Screwdriver	#2 Phillips,
Nylon Panel Removal Tool	e.g. Panel Pry Tool #1 Toyota SST # 00002-06001-01
Side Cutters	
Torque Wrench	36 in•lbf (4.06 N•m)
Utility Knife	
Tape	Clear
Socket	10mm, Extension
Special Chemicals	Notes
Cleaner	VDC Approved Cleaner
Glass Cleaner	Household Glass Cleaner

Legend

	STOP: Damage to the vehicle may occur. Do not proceed until process has been completed with.
	OPERATOR SAFETY: Use caution to avoid risk of injury.
	CAUTION: A process that must be carefully observed in order to reduce the risk of damage to the accessory/vehicle and to ensure a quality installation.
	TOOLS & EQUIPMENT: Used in Figures calls out the specific tools and equipment recommended for this process.
	REVISION MARK: This mark highlights a change in installation with respect to previous issue.
	SAFETY TORQUE: This mark indicates that torque is related to safety.

Care must be taken when installing this accessory to ensure damage does not occur to the vehicle. The installation of this accessory should follow approved guidelines to ensure a quality installation

These guidelines can be found in the "Accessory Installation Practices" document.

This document covers such items as:

- Vehicle Protection (use of covers and blankets, cleaning chemicals, etc.)
- Safety (eye protection, rechecking torque procedure, etc.)
- Vehicle Disassembly/Reassembly (panel removal, part storage, etc.)
- Electrical Component Disassembly/Reassembly (battery disconnection, connector removal, etc.)

Please see your Toyota dealer for a copy of this document

20P WHITE	1P GRAY <i>Connect for Smart</i>	GROUND TERMINAL	12P GRAY	4P WHITE <i>(Male)</i>	5P WHITE <i>to Gateway ECU</i>	Gateway ECU	RES ECU	20P WHITE <i>to RES ECU</i>	4P BLUE <i>(Female)</i>	1P WHITE <i>For Registration</i>	Yellow Wire	Blue Wire	
(A)	(B)	(C)	(D)	(E)	(F)	(G)	(H)	(I)	(J)	(K)	(L)	(M)	

Wire Harness Outline (Passenger's Compartment)

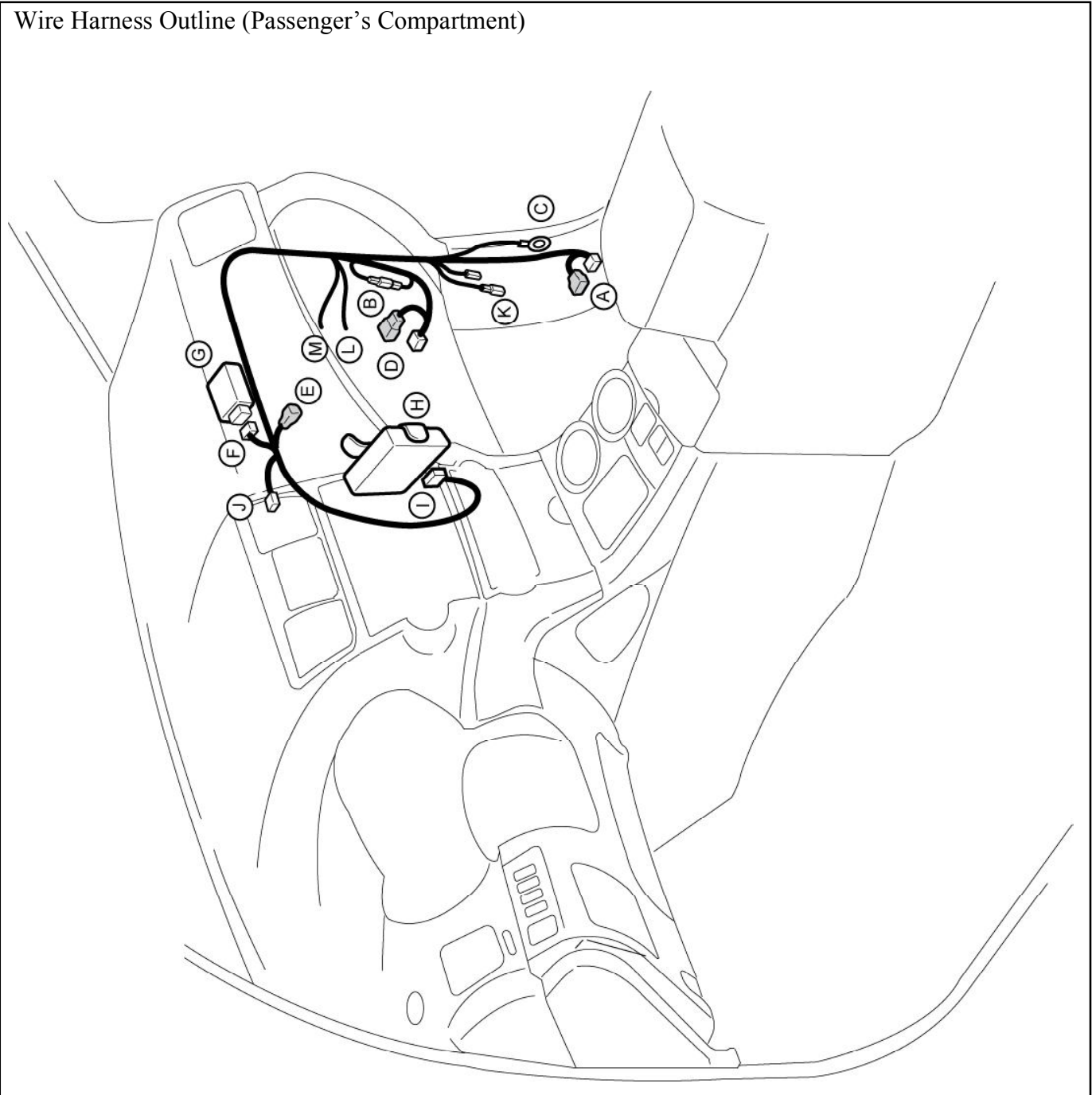

1. Vehicle Disassembly.

- + (a) Place the Vehicle in Park and have the Parking Brake Set before disconnecting the Battery.

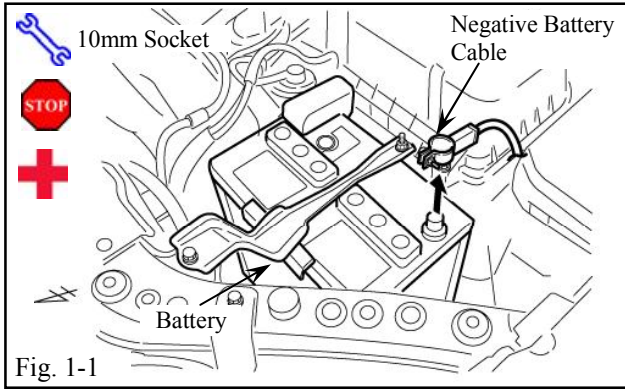

- (b) Remove the Negative Battery Cable (Fig. 1-1)

- (1) Protect the Fender before starting.
- (2) Note the Battery Cable position, as it will be re-installed in the same position.

+ **CAUTION:** Do not touch the Positive Terminal.

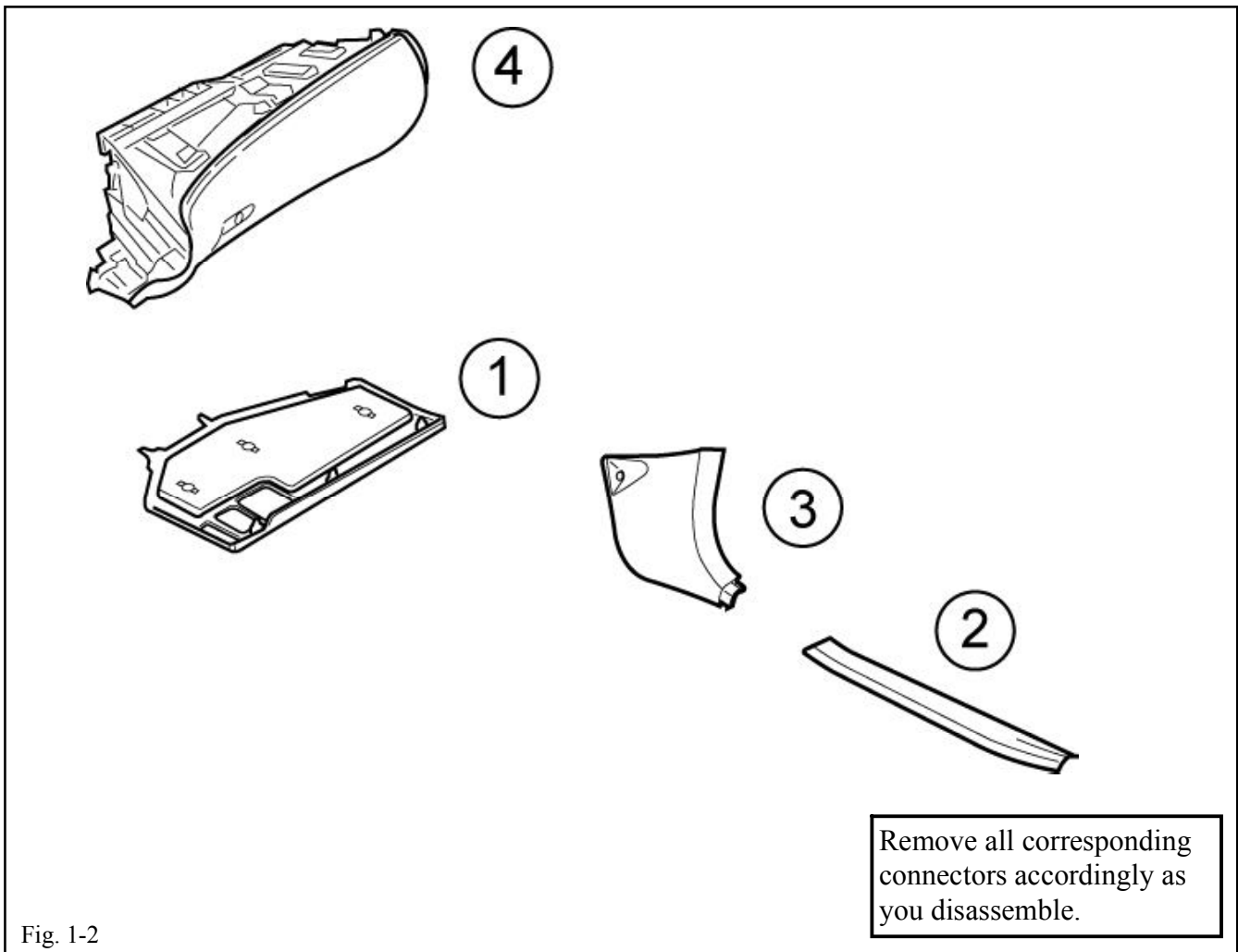

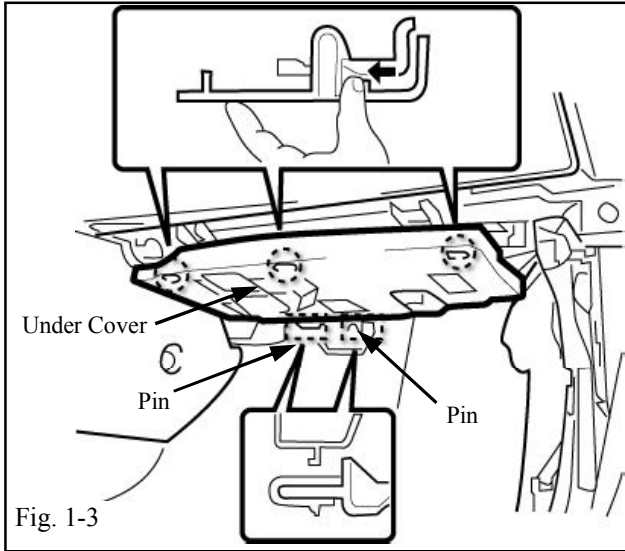

- (c) Remove the Glove Box Under Cover. (Fig. 1-3)
 - (1) Disengage the 3 claws.
 - (2) Pull out the 2 guides.

CAUTION: Removing the Under Cover without properly disengaging the Claws will break the Under Cover.

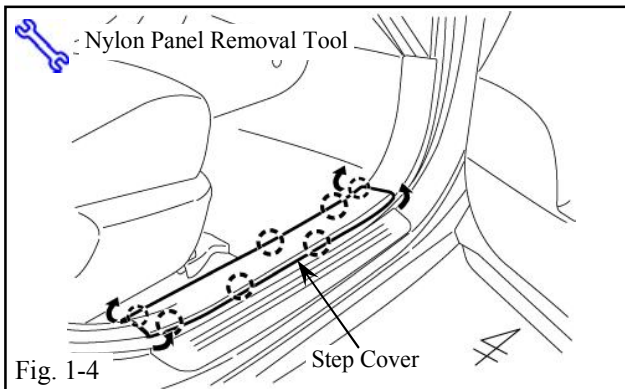

- (d) Remove the Passenger's Step Cover. (Fig. 1-4)

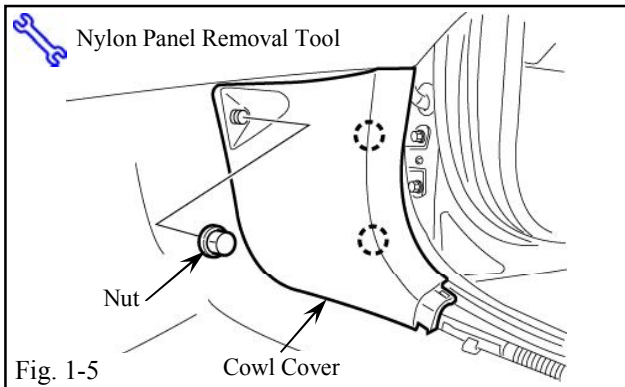

- (e) Remove the Passenger's Cowl Cover. (Fig. 1-5)
 - (1) Remove 1 Nut.

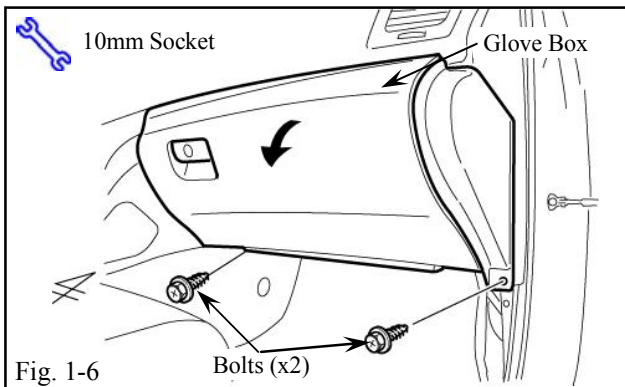

- (f) Remove 2 Bolts from the Glove Box, then open the Glove Box Door. (Fig. 1-6)

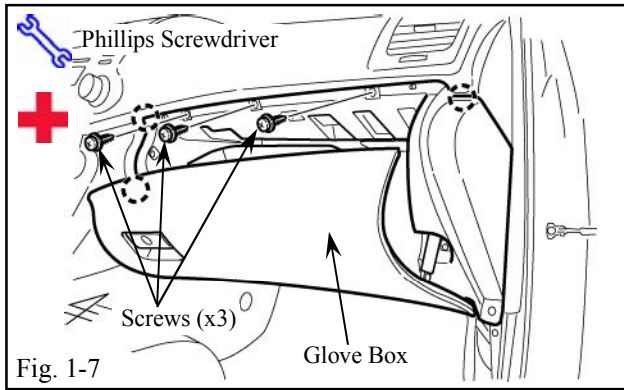

(g) Remove 3 Screws from the Glove Box.
(Fig. 1-7)

+ CAUTION: Sharp Metal Edges.

(h) Dislodge the Glove Box. (Fig. 1-7)

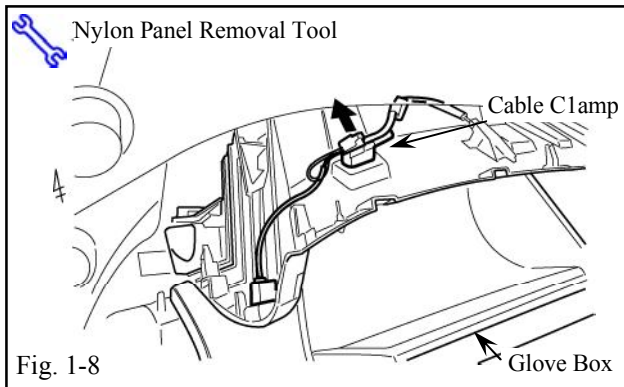

(i) Disconnect all Connectors from the Glove Box. (Fig. 1-8)

(j) Remove the Cable Clamp from the Glove Box. (Fig. 1-8)

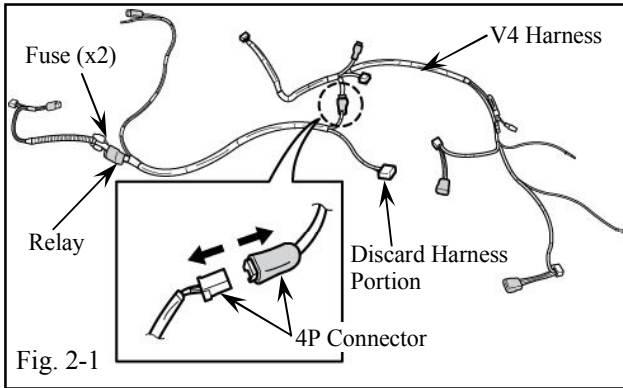

Fig. 2-1

2. V4 Wire Harness Preparation.

- (a) Locate and disconnect the Blue 4P Connectors on the V4 Wire Harness. (Fig. 2-1)

- (1) Discard the V4 Harness's Blue Male 4P Connector Side of Harness. (include the fuse and relay).

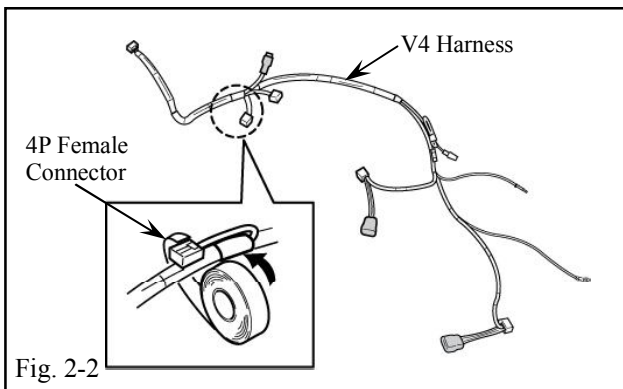

Fig. 2-2

- (b) Secure the V4 Harness's Blue Female 4P Connector with Electrical Tape as shown. (Fig. 2-2)

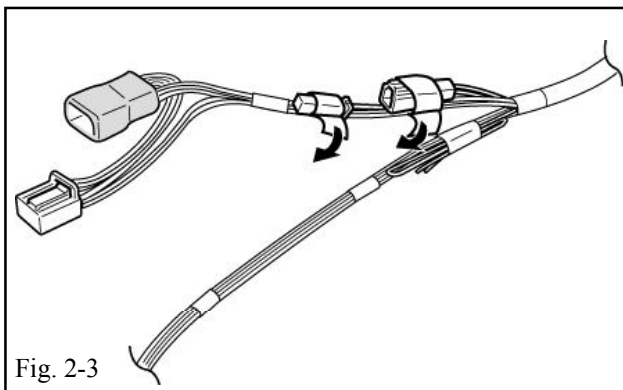

Fig. 2-3

- (c) Locate and un-tape the 2 1P Gray Connectors near the Gray 12P Connectors on the V4 Harness. (Fig. 2-3)

- (1) Do not use the 1P Connectors that are labeled RES DIAGNOSTIC.

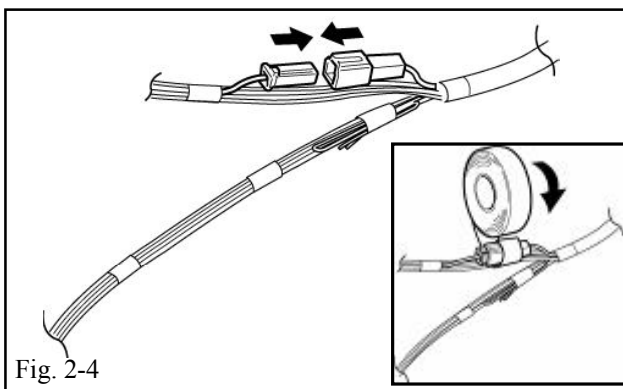
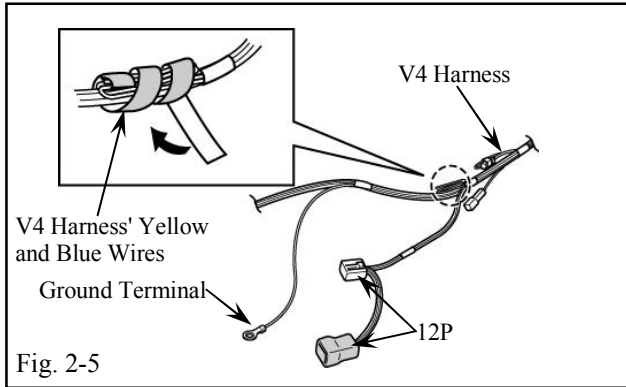

Fig. 2-4

- (d) Connect the V4 1 Pin Connectors together as shown. (Fig 2-4)

- (e) Using Electrical Tape, secure the 1P Connectors to the V4 Harness.



- (f) Locate the Yellow and Blue Wires secured with tape on the V4 Harness. (Fig. 2-5)
- (g) Remove the Tape securing the 2 Wires. (Fig. 2-5)



- (h) Route the V4 Harness's White Male 4P Connector between the Vehicle's Brace and Air Bag Assembly as shown. (Fig. 2-6)
- (i) Locate the Vehicle's Pre-wire White 4P Connector above the Blower Motor Housing. (Fig. 2-6)



CAUTION: There are 2 Vehicle 4P Pre-Connectors. Make sure to use the one directly above the Blower Motor Housing.

- (j) Connect the Vehicle's pre-wire White 4P Connector to the V4 Harness's 4P Connector. (Fig. 2-6)

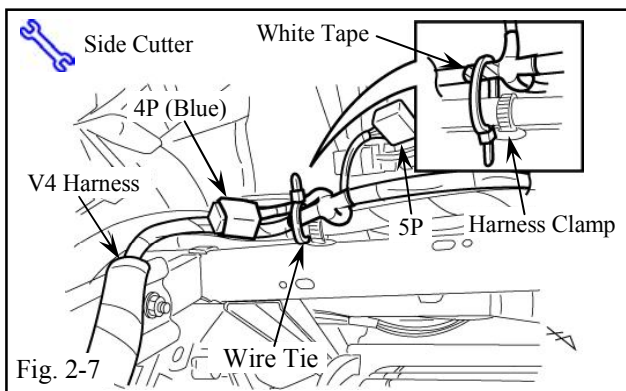

- (l) Verify secure connection.

- (k) Secure the left side of the V4 Harness's White Taped Marker to the left side of the Vehicle Clip with 1 Wire Tie. (Fig.2-7)

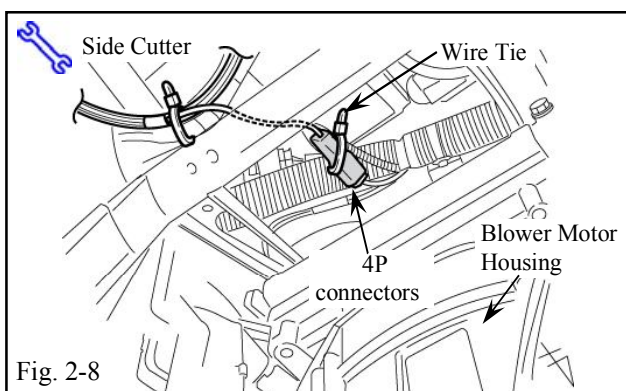

- (l) Secure the 4P Connectors to the Vehicle Harness with 1 Wire Tie. (Fig. 2-8)

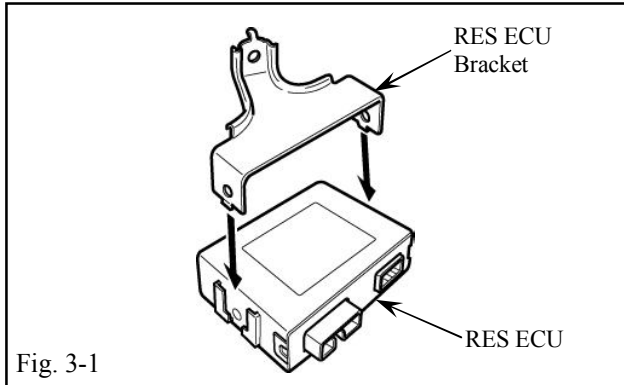

Fig. 3-1

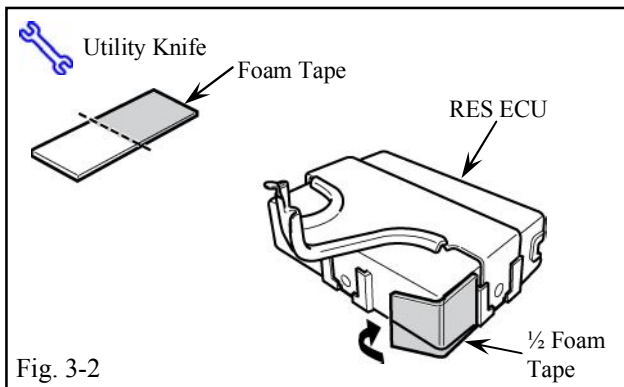

Fig. 3-2

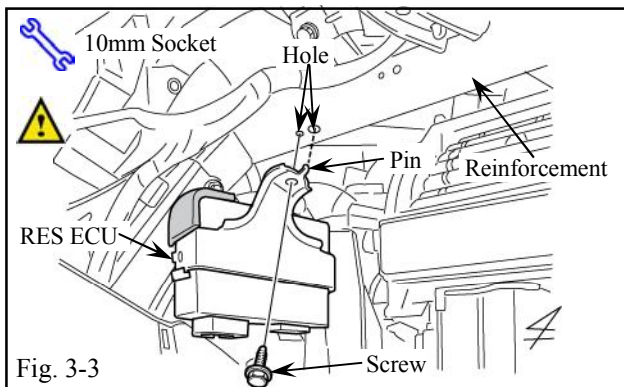

Fig. 3-3

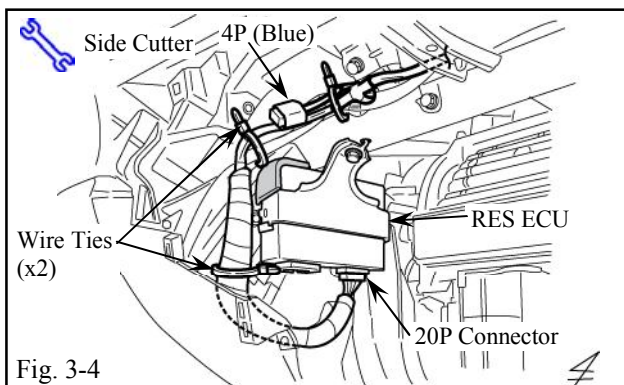

Fig. 3-4

3. RES ECU and Gateway ECU Preparation and Installation.

- (a) Insert the RES ECU Bracket into the indicated Bracket Slots on the RES ECU. (Fig. 3-1)

(1) Ensure the Bracket is firmly attached to the ECU.

- (b) Cut 1 Foam Tape in half. Apply it to the RES ECU as shown. (Fig.3-2)

(1) Do not discard the Extra Foam Tape.

- (c) Using the Screw from the Kit, install the RES ECU Bracket. (Fig. 3-3)

(1) Make sure that the bracket pin seats properly.



CAUTION: Do not over tighten the Screw.

- (d) Connect the V4 Harness's White 20P Connectors to the RES ECU. (Fig. 3-4)

- (e) Using 2 Wire Ties to secure the V4 Harness to the Vehicle Harness. (Fig. 3-4)

- (f) Route the V4 Harness toward the right side of the Glove Box.

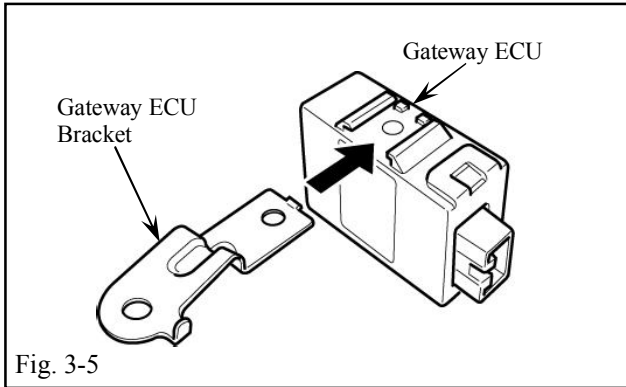

- (g) Install the Gateway ECU Bracket into indicated bracket slot on the Gateway ECU. (Fig. 3-5)
 - (1) Ensure the bracket is firmly attached to the ECU.

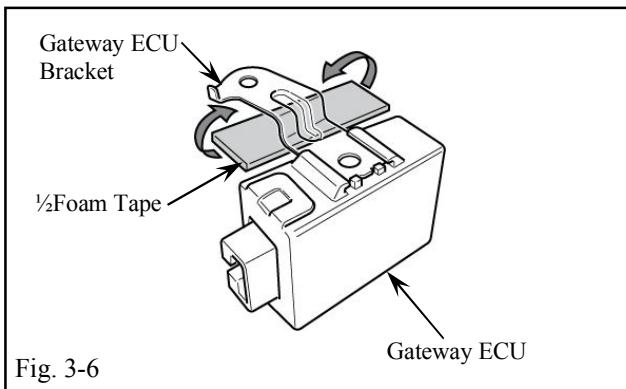

- (h) Using the extra 1/2 of Foam Tape from Fig.3-2, apply it to the Gateway ECU Bracket as shown. (Fig. 3-6)

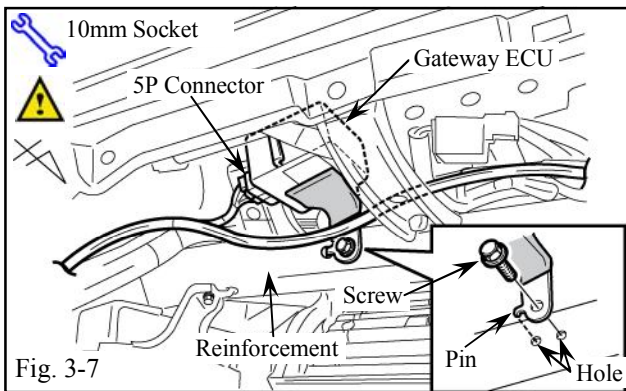

- (i) Using the Screw from the Kit, install the Gateway ECU Bracket. (Fig. 3-7)
 - (1) Make sure that the bracket pin seats properly.
- CAUTION:** Do not over tighten the Screw.
- (j) Connect the V4 Harness's White 5P Connector to the Gateway ECU. (Fig. 3-7)

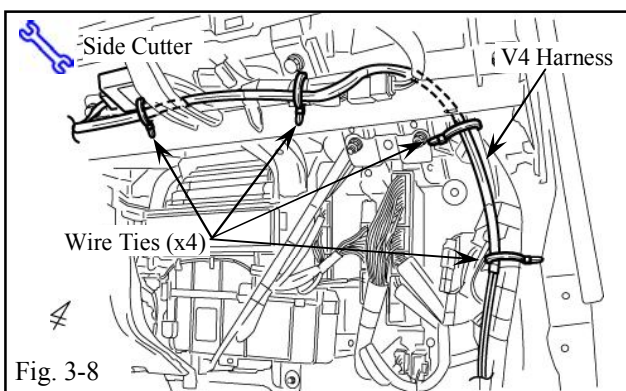

- (k) Route the V4 Harness toward the Passenger Side Cowl Area, securing it to the Vehicle Harness with 4 Wire Ties. (Fig. 3-8)

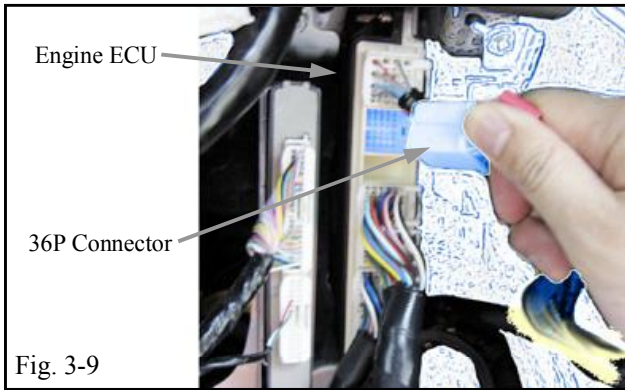

- (l) Locate the Engine ECU to the right side of the Blower Motor and disconnect the 36P Connector as shown.(Fig. 3-9)

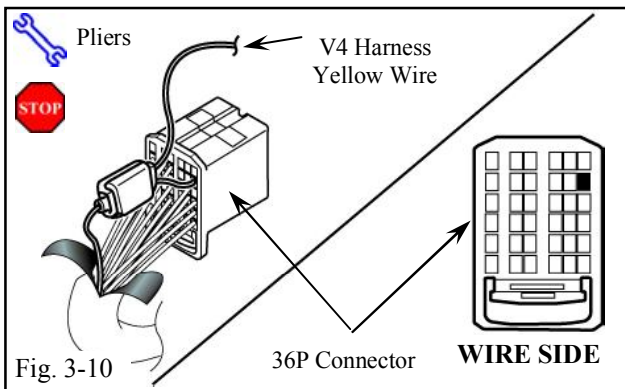

- (m) Use a Splicing Connector to secure the V4 Harness's Yellow Wire to the Wire from Pin 30 of the 36P Vehicle Connector. (Fig. 3-10)

VERIFY: That the Wire is spliced properly.



CAUTION: There are 2 Vehicle 36P Connectors. Make sure you are splicing into the correct one. See fig. 3-9 for connector location.

- (n) Reconnect the Connector to the Engine ECU.

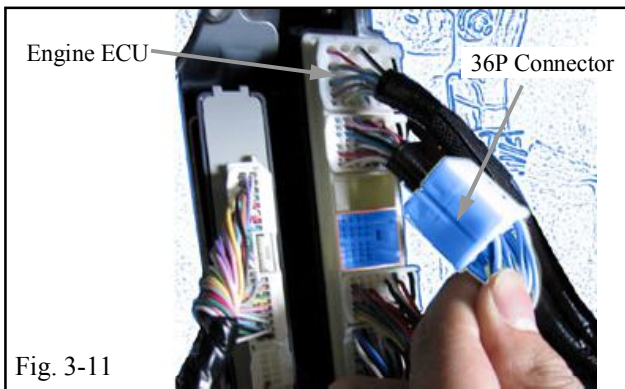

- (o) Disconnect the next 36P Connector from the Engine ECU as shown. (Fig. 3-11)

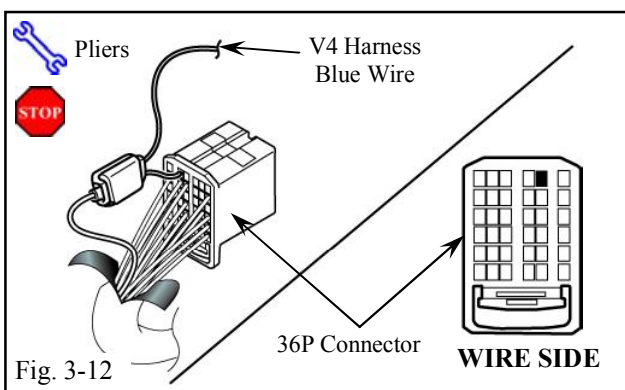

- (p) Use a Splicing Connector to secure the V4 Harness's Blue Wire to the Wire from Pin 35 of the 36P Vehicle Connector. (Fig. 3-12)

VERIFY: That the Wire is spliced properly.



CAUTION: There are 2 Vehicle 36P Connectors. Make sure you are splicing into the correct one. See fig. 3-11 for connector location.

- (q) Reconnect the Connector to the Engine ECU.

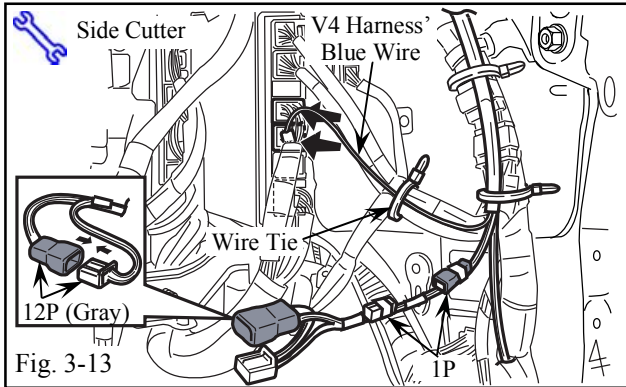

- (r) Secure the V4 Harness's Blue and Yellow Wires to the Vehicle Harness with 1 Wire Tie. (Fig. 3-13)
- (s) Connect the V4 Harness's Gray 12P Connectors as shown. (Fig. 3-13)

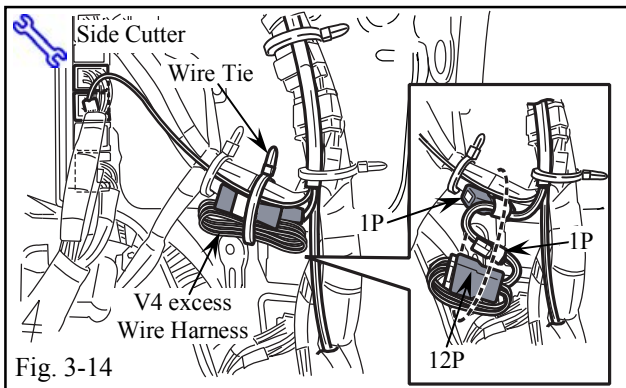

- (t) Bundle up the excess V4 Harness's Gray 12P Connector Wires and secure it to the Vehicle Harness with 1 Wire Tie. (Fig. 3-14)

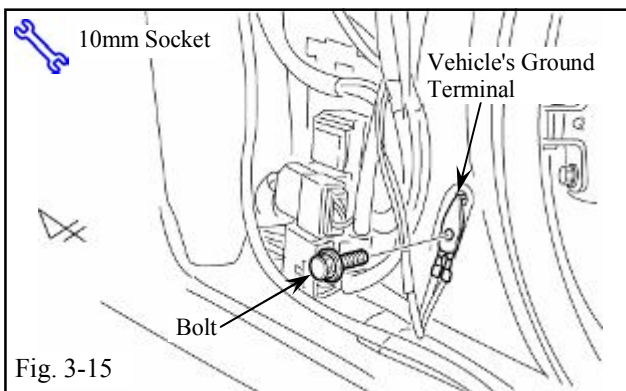

- (u) Remove 1 Bolt securing the Vehicle's Ground Terminal from the Passenger Side Cowl Area. (Fig. 3-15)
 - (1) Do not discard the bolt.

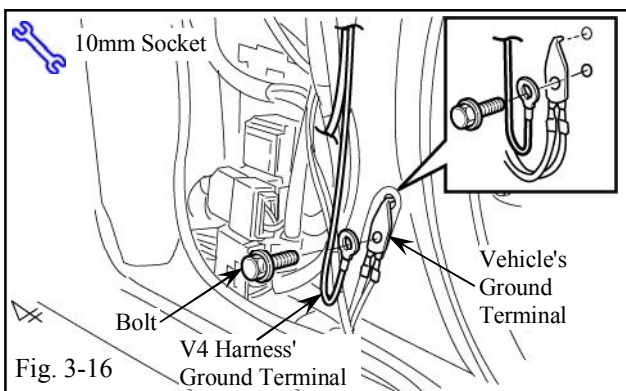

- (v) Use the existing Vehicle's Bolt to secure the V4 Harness's Ground Terminal with the Vehicle's Ground Terminal. (Fig. 3-16)
 - (1) Make sure that the vehicle ground terminal pin seats properly.

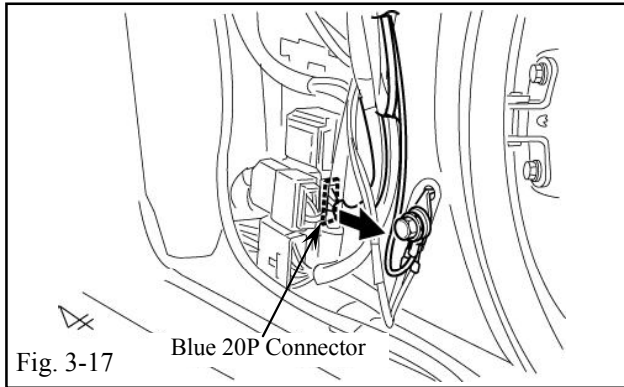

- (w) Locate and disconnect the Vehicle's Blue 20P Connector from the Passenger Side Cowl Area. (Fig. 3-17)

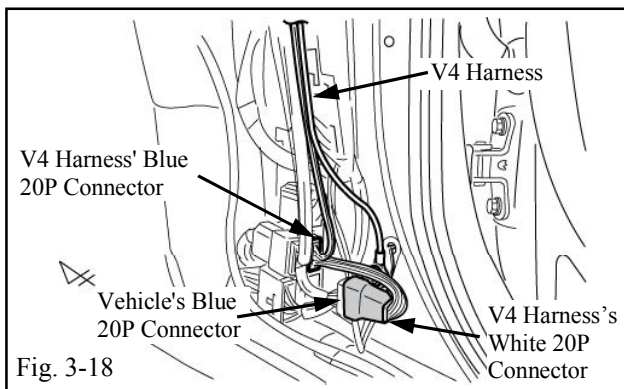

- (x) Plug in the V4 Harness's Blue 20P Connectors in between the Passenger Side Connector Block and Blue 20P Connector. (Fig. 3-18)
 - (1) Verify secure connection.

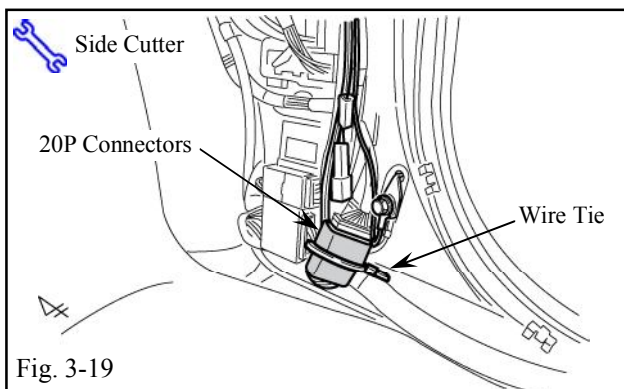

- (y) Use 1 Wire Tie to secure the 20P Connectors to the Vehicle Harness. (Fig. 3-19)

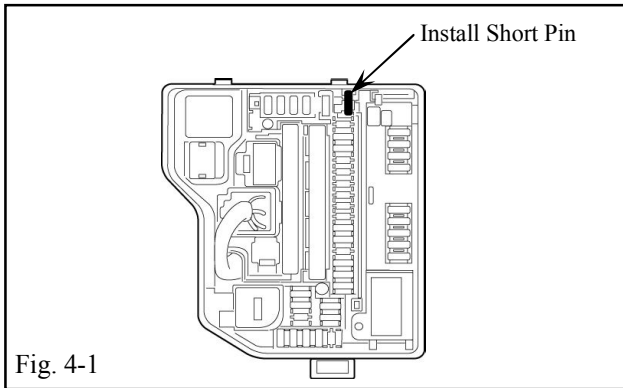

Fig. 4-1

4. Partial Reassembly.

- (a) Reassemble the Vehicle, except for the Passenger's Cowl Cover, and Step Cover.
 - (1) Reconnect any disconnected connectors.
- (b) Verify that the Short Pin is installed. (Fig. 4-1)
 - (1) If not install the Short Pin.

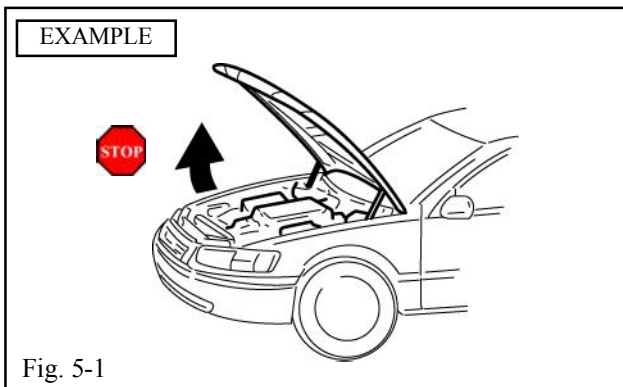



Fig. 5-1

5. Registration w/ Techstream.

- (a) Open the Hood. (Fig. 5-1)
 - (1)  Do not close the Hood during the Registration Setting Procedure. (Steps b-ff)

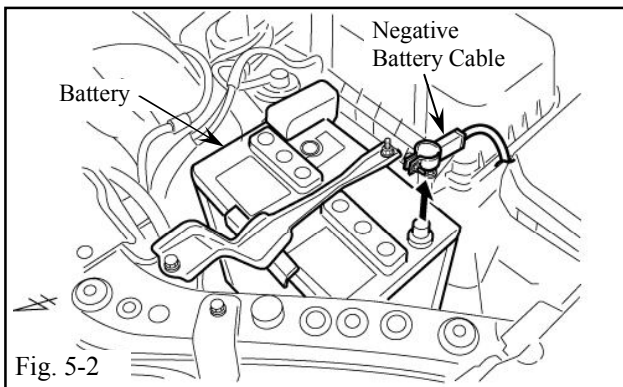



Fig. 5-2

- (b) Temporarily reconnect the Vehicle's Negative Battery Cable. (Fig. 5-2)

 **CAUTION:** Do not touch the positive terminal.

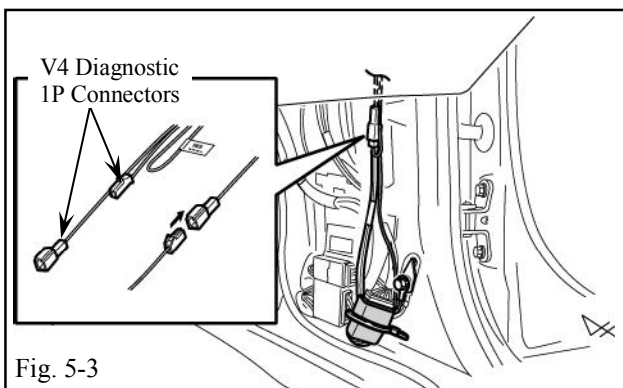

Fig. 5-3

- (c) Locate the RES Harness's 1P RES Diagnostic Connectors in the Passenger Side Cowl Area, and remove tape. (Fig. 5-3)
- (d) Connect the 2 RES Diagnostic Connectors. (Fig. 5-3)

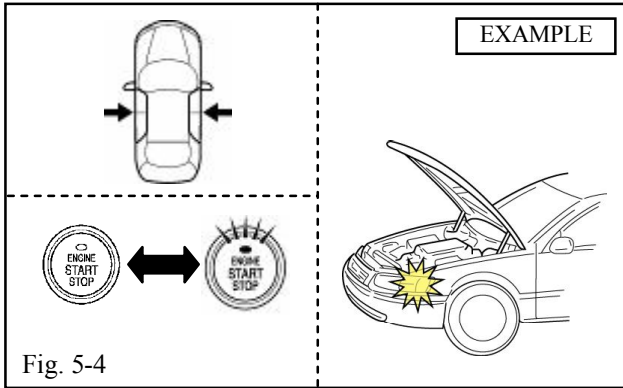

Fig. 5-4

- (e) Ensure all Doors are closed and the Smart Key is in your possession. (Fig. 5-4)
- (f) Cycle the “Engine Start Stop” Button from “OFF” to “ON” 5 times. (Fig. 5-4)
- (1) Place the Shift Lever in the "P" (park) or "N" (neutral) Position.



NOTE: One cycle consists of:

OFF → Accessory → ON

This is equivalent to pressing the “Engine Start Stop” Button 14 times.

- (g) Once the fifth cycle has been completed, the Hazard Lights Flash once. (Fig. 5-4)
- (h) Press the “Engine Start Stop” Button once more to turn the ignition to OFF.

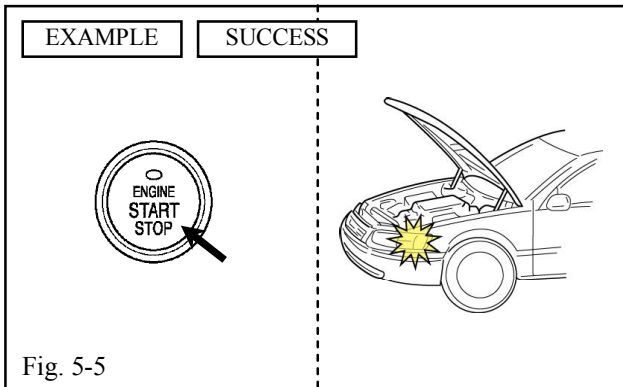

Fig. 5-5

- (i) Start the Engine, after 10 seconds stop the engine. (Fig. 5-5)
- (j) The Hazard Lights flash once. Registration is completed. (Fig. 5-5)

Go to step m.

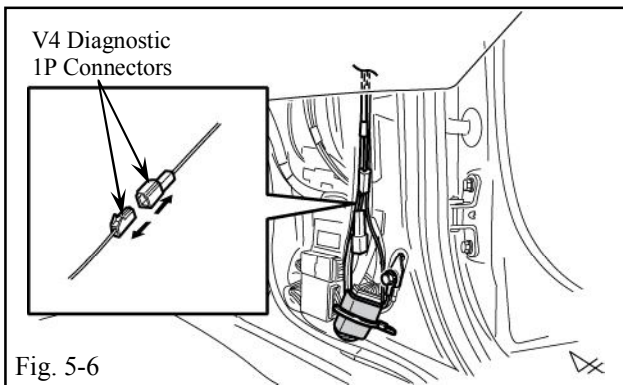
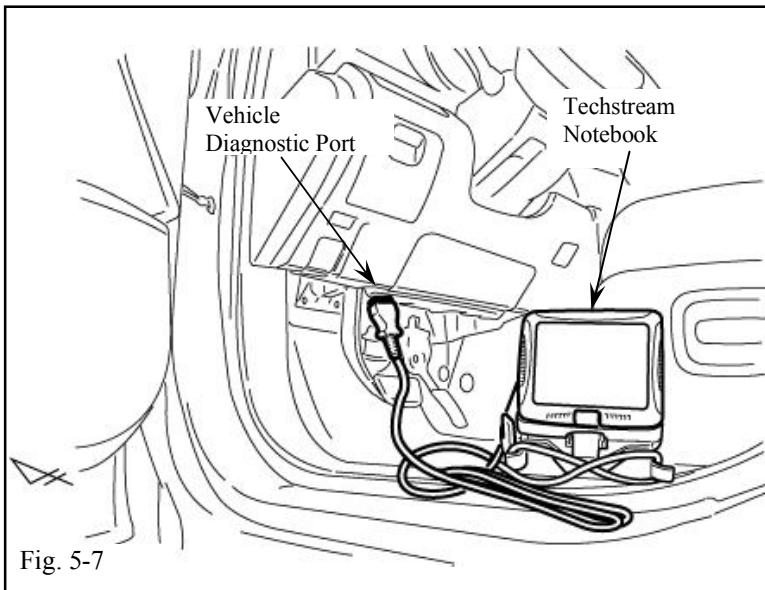

Fig. 5-6

- (k) If you fail this procedure, the Hazard Lights flash twice.
- (l) Disconnect the RES Harness white 1P Connector from the Passenger Side Cowl Area. (Fig. 5-6)

Start again from step c.



- (m) Connect the Techstream Notebook to the Vehicle's Diagnostic Port. (Fig. 5-7)
- (n) With the Smart Key in your possession, press the "Engine Start Stop" button twice to select the Ignition "ON" position.

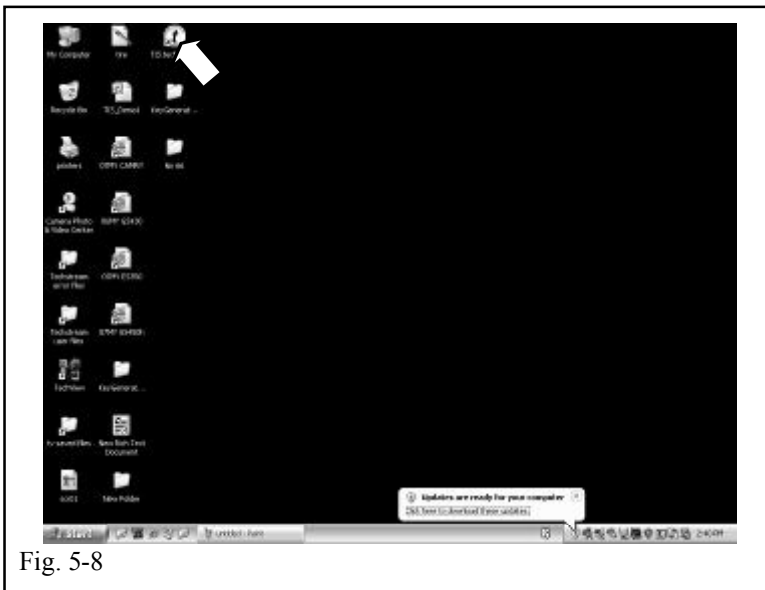

- (o) Start the TIS Techstream Application by clicking on the shortcut located on the Desktop. (Fig. 5-8)

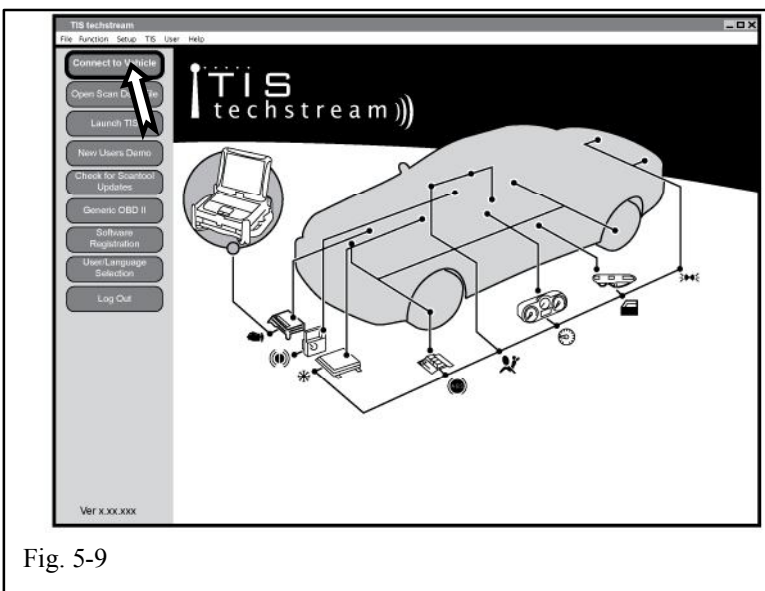

- (p) Click "Connect to Vehicle" (Fig. 5-9)

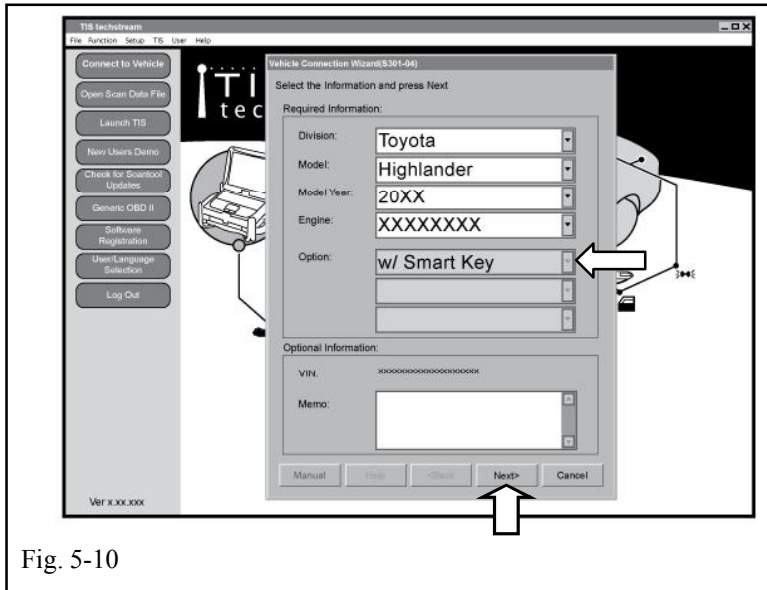

Fig. 5-10

- (q) Confirm that the information displayed on the Vehicle Connection Wizard is correct for the vehicle. If not verify that the Techstream is properly connected. (Fig. 5-10)
- (r) Select w/Smart Key. (Fig.5-10)
- (s) Click “Next>.” (Fig. 5-10)

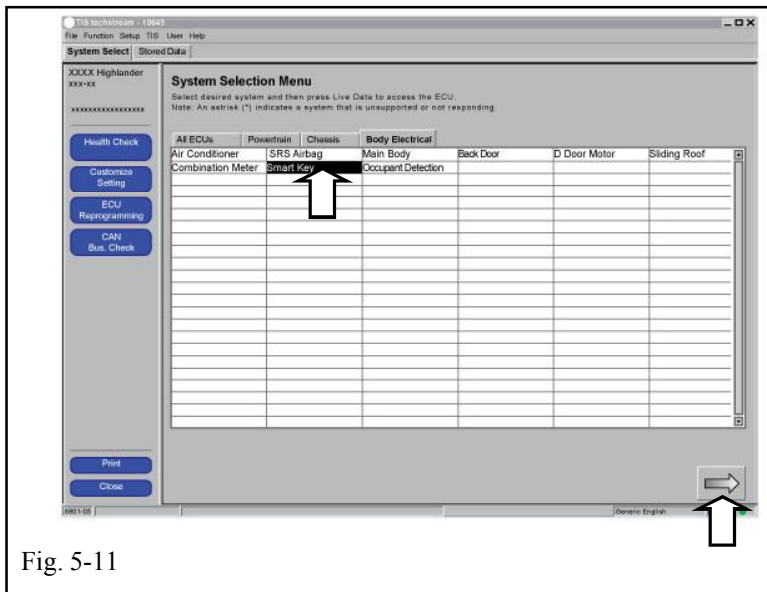



Fig. 5-11

- (t) Select Smart Key. (Fig. 5-11)

- (u) Click . (Fig. 5-11)

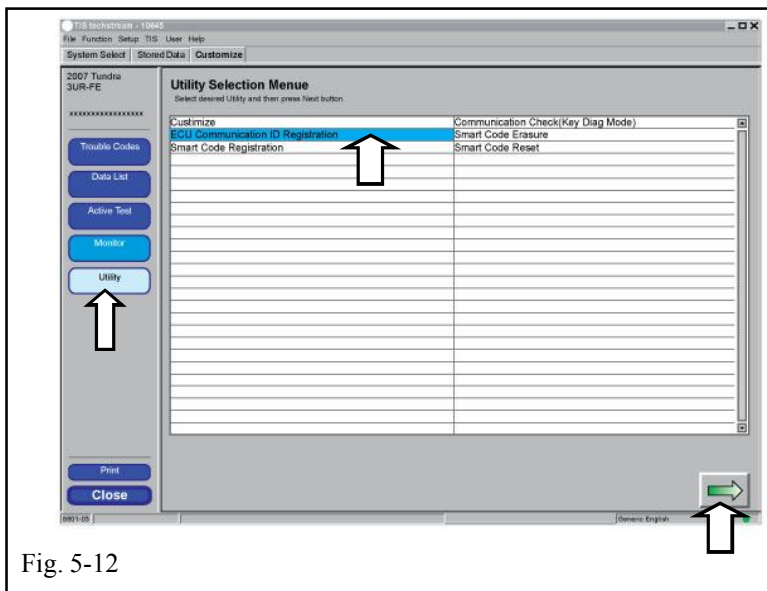



Fig. 5-12

- (v) Click “Utility”. (Fig. 5-12)
- (w) Select “ECU Communication ID Registration.” (Fig. 5-12)

- (x) Click . (Fig. 5-12)

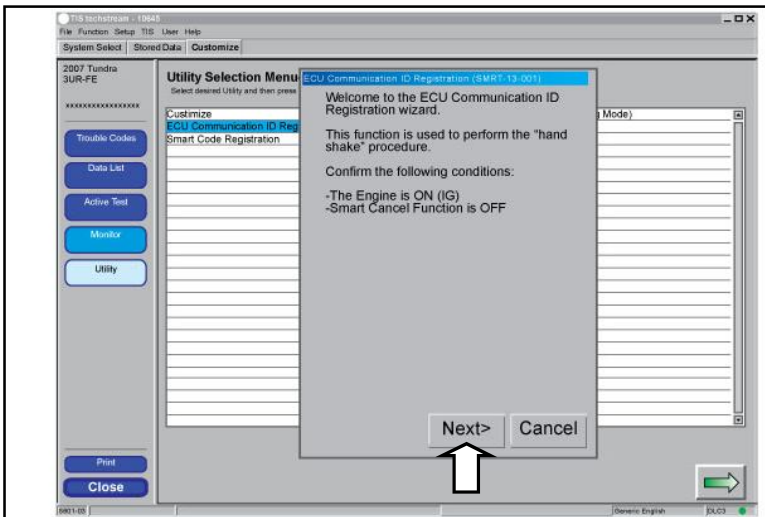

Fig. 5-13

- (y) Confirm that the Engine is ON (IG), and that the Smart Cancel Function is OFF. (Fig. 5-13)
- (z) Click “Next>” to continue. (Fig. 5-13)

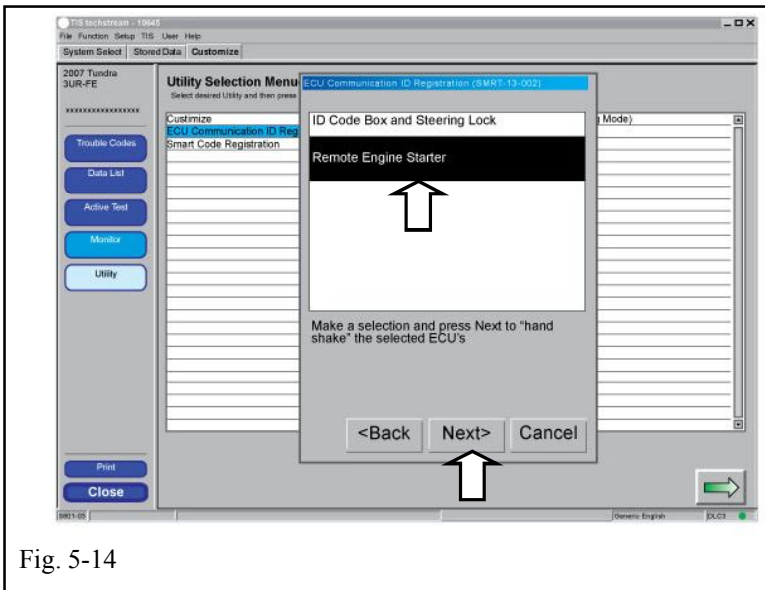

Fig. 5-14

- (aa) Select “Remote Engine Starter.” (Fig. 5-14)
- (bb) Click “Next>” to continue. (Fig. 5-14)

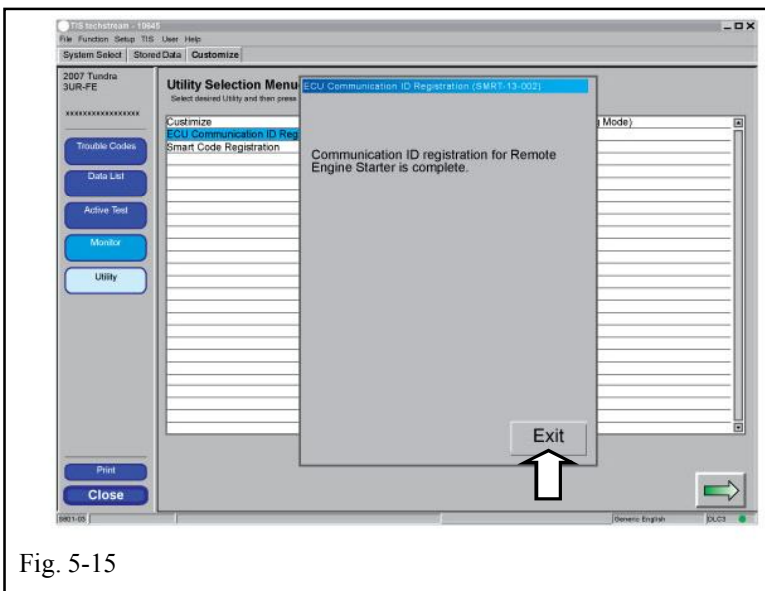

Fig. 5-15

- (cc) Click “Exit.” (Fig. 5-15)

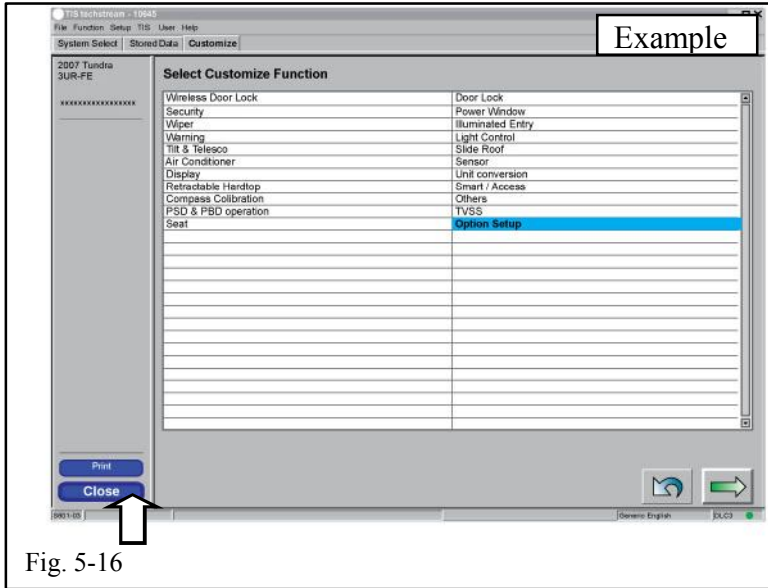

Fig. 5-16

(dd) Click “Close.” (Fig. 5-16)

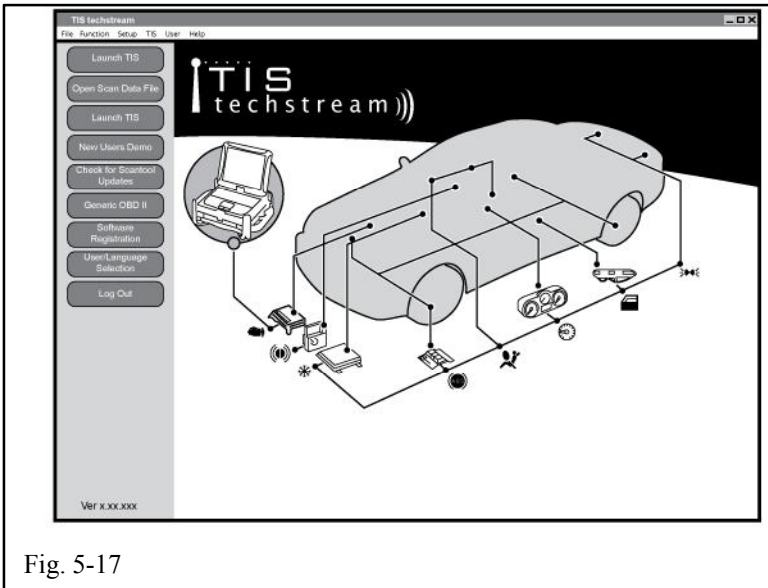
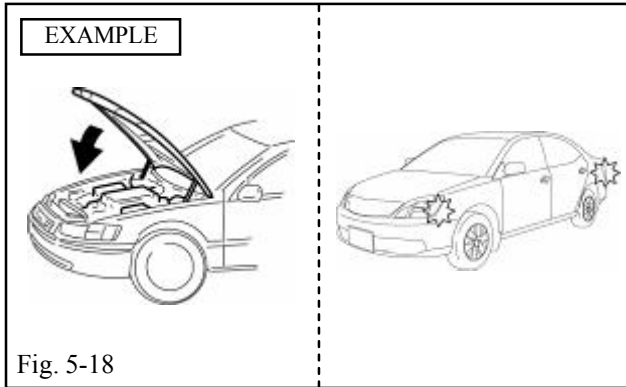

Fig. 5-17

(ee) Click  (Fig. 5-17)



- (ff) Close the Hood. (Fig. 5-18)
- (gg) The Hazard Lights flash twice. Registration completed (Fig. 5-18)

If you fail this procedure, the hazard lights flash 3 times. Registration will not set.

Start again from Step a.

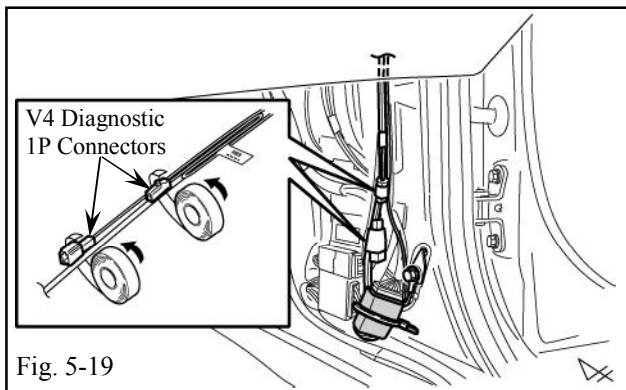

- (hh) Disconnect the RES Harness's 1P RES Diagnostic Connectors. (Fig. 5-19)
- (ii) Secure the RES Harness and 1P Connectors with Electrical Tape as shown. (Fig. 5-19)
- (jj) Press the "Engine Start Stop" Button to the "OFF" (Indicator Light off) position.

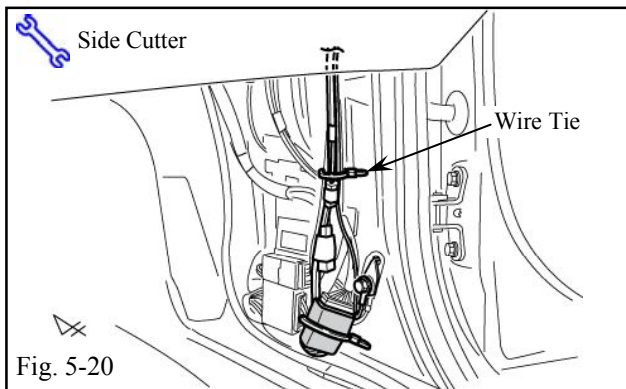

- (kk) Secure the V4 Harness to the Vehicle Harness with 1 Wire Tie. (Fig. 5-20)

6. Tags and Label Installation.



For US Vehicles use the English Labels and Owner's Guide. Discard the bag containing the Spanish documents.



For Mexico Vehicles use the Spanish Labels and Owner's Guide. Discard the bag containing the English documents.

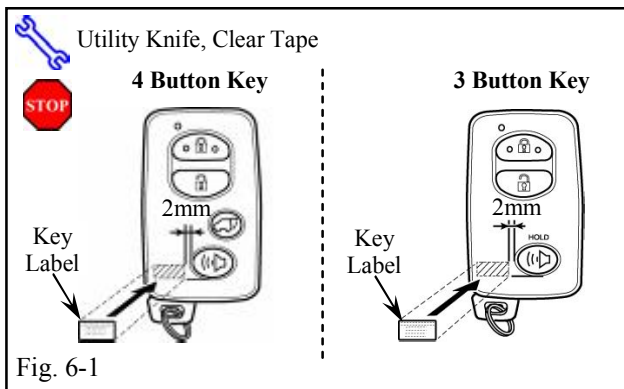

Fig. 6-1

(a) Remove 2 of the Remote Controls from their protective bag. (Fig. 6-1)

(1) Use a utility knife, to cut a slit in each bag.

(b) Using VDC approved cleaner and Cleaning Method, clean the area indicated on the Remote Controls. (Fig. 6-1)

(c) Attach the Key Label to the Remote Controls as shown. (Fig. 6-1)

(1) Use a piece of the clean adhesive tape to lift the labels off their protective backing.



CAUTION: Do not touch the adhesive surface.

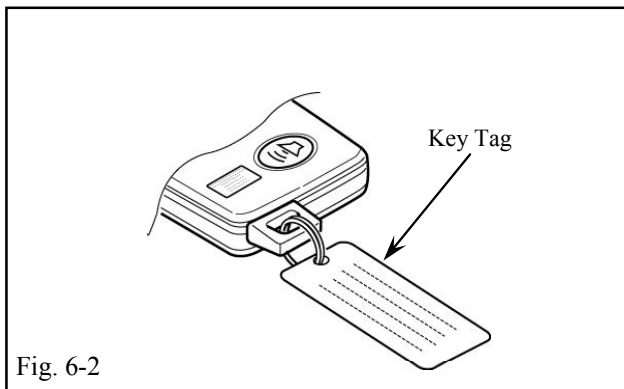

Fig. 6-2

(d) Attach the Remote Engine Starter Tags to the Vehicle Remote Controls. (Fig. 6-2)

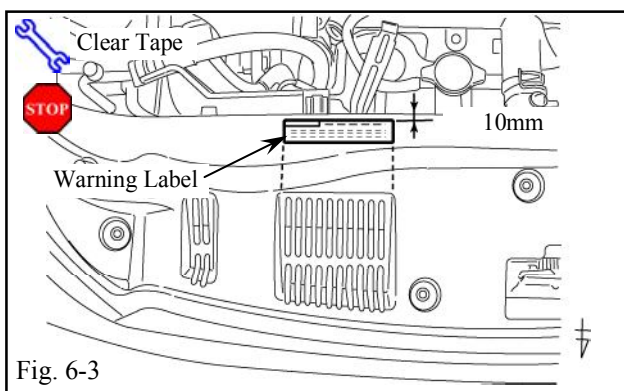

Fig. 6-3

(e) Using VDC approved cleaner and Cleaning Method, clean the area indicated on the Engine Compartment Cover. (Fig. 6-3)

(f) Attach the Warning Label to the Engine Compartment Cover as shown. (Fig. 6-3)



CAUTION: Do not touch the adhesive surface.

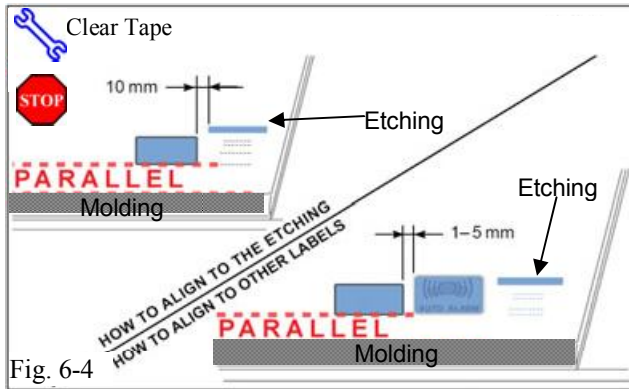

- (g) Use Household Glass Cleaner to clean the inside of the Front Door Windows.
- (h) Use a piece of Clear Tape to lift the Label from the protective backing.



CAUTION: Do not touch the adhesive surface.

- (i) Attach the Label as shown. (Fig. 6-4)



NOTE: Make sure to Align according to Etching or Other Label.

REPEAT: steps g–i with the other Window.

7. Completing the Installation.

- (a) Complete the reassembly of the vehicle.



- (1) Verify the panels fit together properly, with no uneven gaps.

- (b) Position the Negative Battery Cable at the original factory position. (Fig. 7-1)



- (1) Tighten the nut to 36in•lbf (4.06 N•m)



CAUTION: Do not touch the positive terminal.

- (c) Clean up and remove any Trash.
- (d) Sealed in its protective bag, place the Owner's Guide in the Glove Box.

- (e) Reset the Power Windows.

- (1) Turn Ignition Key to the "ON" position.
- (2) Push down the Power Window Switches, and lower the windows halfway.
- (3) Pull up the switches until the windows close.
- (4) Continue holding up on the switches for a minimum of 1 second.

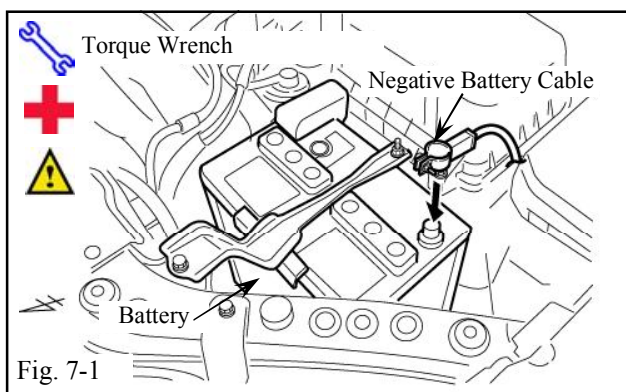

Accessory Function Checks

Close the hood, enter the vehicle and close all doors. Place the shift lever in the “P” (Park) position, set the parking brake and make sure the Vehicle is off.

Perform		Look For
1	Press the remote control's lock button twice within 2 seconds, then press and hold the lock button for 3 seconds.	The hazard lights flash after 3 seconds. The engine starts. The hazard lights flash repeatedly for 20 seconds.
2	With the engine running, pull the hood release handle. NOTE: <i>Some Vehicles may require you to exit the Vehicle and pull up on the Hood.</i>	The engine stops. The hazard lights flash once. The security alarm triggers (only if equipped with OE Factory Alarm, not Genuine Accessory alarm, and only if armed)
3	Move the shift lever out of “P” (Park). Attempt to start the Vehicle using the remote.	The engine does not start.







Vehicle Function Checks

Function	Function
----------	----------

Enter the Vehicle

<input type="checkbox"/> Dome/Courtesy Lights	<input type="checkbox"/> Steering Wheel Column Adjusts Without Interference
<input type="checkbox"/> Horn	

Start the Vehicle

<input type="checkbox"/> Starter	<input type="checkbox"/> Gauges
<input type="checkbox"/> Panel/Switch Illumination	<input type="checkbox"/> ABS Light (if equipped) <i>If the warning light remains on, it may indicate a system malfunction.</i> 
<input type="checkbox"/> Lamp Failure Sensor <i>If the warning light remains on, it may indicate a system malfunction.</i> 	<input type="checkbox"/> Track/Skid Control Light (if equipped) <i>If the warning light remains on, it may indicate a system malfunction.</i> 
<input type="checkbox"/> Seat Belt Warning Light <i>If the warning light remains on, it may indicate a system malfunction.</i> 	<input type="checkbox"/> Tire Pressure Monitoring System (TPMS) <i>Prior to TPMS activation and Pre-delivery Service (PDS) of the Vehicle the TPMS light will blink when IG is turned on.</i> <i>After TPMS activation and PDS of the Vehicle the TPMS light will illuminate for a few seconds and go off when IG is turned on.</i> 
<input type="checkbox"/> Air Bag Warning Light <i>If the warning light remains on, it may indicate a system malfunction.</i> 	
<input type="checkbox"/> Cruise Control Light (if equipped) 	

Using a Mirror or Assistant check the following.

<input type="checkbox"/> Trunk/Tailgate/Bed Lights (if equipped)	<input type="checkbox"/> Tail Lights
<input type="checkbox"/> Brake Lights	<input type="checkbox"/> Daytime Running Lights (if equipped)
<input type="checkbox"/> Backup Lights	<input type="checkbox"/> Marker Lights
<input type="checkbox"/> Clearance Sonar (if equipped)	

Stop the Engine, Place the Vehicle's IG in the ON position.

<input type="checkbox"/> Hazard Lights	<input type="checkbox"/> Turn Signal Lights
<input type="checkbox"/> Head Light	<input type="checkbox"/> Fog Lights (if equipped)
<input type="checkbox"/> High Beams	<input type="checkbox"/> Accessory Controls/Illumination (if equipped)
<input type="checkbox"/> Power Side Mirrors (if equipped)	<input type="checkbox"/> Convenience Memory Settings (if equipped)
<input type="checkbox"/> Power Sliding Door (if equipped)	<input type="checkbox"/> Rear Sunshade (if equipped)

Function		Function	
<input type="checkbox"/>	Front Wiper/Washer	<input type="checkbox"/>	Rear Wiper/Washer (if equipped)
<input type="checkbox"/>	Power Sun/Moon Roof (if equipped)	<input type="checkbox"/>	Rollover Side Curtain Air Bag Switch (RSCA) (if equipped)
<input type="checkbox"/>	Clock (if equipped)	<input type="checkbox"/>	Navigation System (if equipped)
<input type="checkbox"/>	Audio/Video (if equipped)	<input type="checkbox"/>	HVAC
<input type="checkbox"/>	Steering Wheel Audio Control (if equipped)	<input type="checkbox"/>	Rear Window Defogger (if equipped)
<input type="checkbox"/>	Front Windshield Defogger (if equipped)	<input type="checkbox"/>	Accessory Power Socket (if equipped)
<input type="checkbox"/>	Side Mirror Defogger (if equipped)	<input type="checkbox"/>	Heated/Vented Seats (if equipped)
<input type="checkbox"/>	Massage Seats (if equipped)		
<input type="checkbox"/>	Glovebox Light (if equipped)	<input type="checkbox"/>	Passenger Air Bag Switch (if equipped)
<input type="checkbox"/>	Power Locks (if equipped)	<input type="checkbox"/>	Power Windows (if equipped)
<input type="checkbox"/>	Power Seats (if equipped)	<input type="checkbox"/>	Key Sensor Buzzer

Remove the short pin after Function check.
 Check with your Port/Dealer to see if this step is necessary.

