



Part Number: 00016-32103-01;00003-04

Accessory Code: BT1

**Kit Contents**

Item #	Quantity Reqd.	Description
1	1	UIB -USER INTERFACE
2	1	CONTROL MODULE
3	1	USER GUIDE
4	1	HARDWARE BAG
5	1	INSTALLATION INSTRUCTIONS
6	1	REGISTRATION CARD

**Hardware Bag Contents**

Item #	Quantity Reqd.	Description
1	3	T TAPS
3	3	MALE INSULATED SPADES
4	4	FOAM ADHESIVE PADS
5	4	3.5 MMX 19MM SCREWS
6	3	TIE STRAPS
7	1	GROUND TERMINAL
8	1	WIRE HARNESS

**Additional Items Required For Installation**

Item #	Quantity Reqd.	Description
1		
1		

**Conflicts**

Note: NONE

**Recommended Tools**

<b>Safety Tools</b>	
SAFETY GLASSES	
SAFETY GLOVES	
<b>Special Tools</b>	
DREMEL TOOL	
<b>Installation Tools</b>	
NYLON TOOL	1" HOLE SAW
PLIERS	SPIRAL BIT
#2 PHILLIPS TIP	SIDE CUTTERS
MEASURING SCALE	T-30 TORX SCREWDRIVER
T-15 TORX SCREWDRIVER	10 MM WRENCH
TORQUE WRENCH 36" LB.	1/8 DRILL BIT
MARKING UTENSIL	
<b>Special Chemicals</b>	
ALCOHOL / WATER	

**Color Applicability/Trim Level**

Accessory Color	Vehicle/Trim Color																	
	00016-32103-01 ASH																	
	00016-00003-04 OAK																	

**General Applicability**

--

**Recommended Sequence of Application**

Item #	Accessory	
1		
2		
3		

\*Mandatory

**Legend**

**STOP:** Damage to the vehicle may occur. Do not proceed until process has been completed with.

**OPERATOR SAFETY:** Use caution to avoid risk of injury.

**CAUTION:** A process that must be carefully observed in order to reduce the risk of damage to the accessory/ vehicle and to ensure a quality installation.

**TOOLS & EQUIPMENT:** Used in Figures calls out the specific tools and equipment recommended for this process.

**REVISION MARK:** This mark highlights a change in installation with respect to previous issue.

**SPECIAL NOTE: Installation Sequences**

After TMS and Safety mandated preparatory steps have been taken, the installation sequence is the suggested method for completing the accessory installation. In some instances the suggested sequence is written for one associate to install and in others the sequence is given as part of a team accessory installation. Unless otherwise stated in the document, the associates may perform the installation steps in any order to make the installation as efficient as possible while maintaining consistent quality. Also some items listed to be removed may not need to be removed if caution is taken to not damage vehicle.

**1. PREPARATION**

- (a). Place protective covering in vehicle.
- (b). Remove negative battery terminal. **(FIGURE 1-0)**

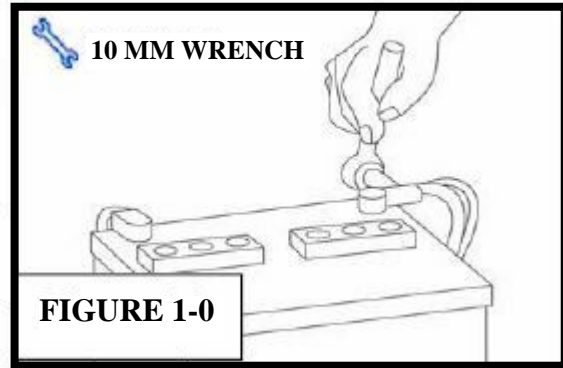

**STOP** **!** **Note: Vehicle and mounting surface temperature must be between a minimum of 60 F and a maximum of 110 F just prior to installation.** **!**

**2. "A" PILLAR BREAK DOWN (NON-SUNROOF MODELS ONLY)**

- (a). Pull top A-pillar trim out. **(FIGURE 2-0)**
- (b). Rotate A-pillar trim retainer 90 degrees and disengage from A-pillar trim. **(FIGURE 2-0)**
- (c). Pull base of A-pillar trim out towards rear of vehicle to remove. **(FIGURE 2-0)**

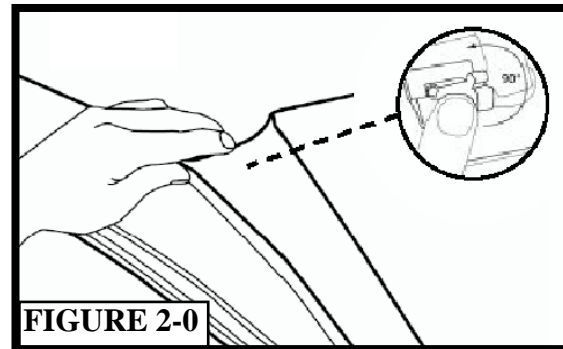

**3. REMOVE ROOF CONSOLE BOX ASSEMBLY**

-  (a). Using a nylon tool, remove the roof console box. **(FIGURE 3-0)**
- (b). Disconnect the connector on roof console box.

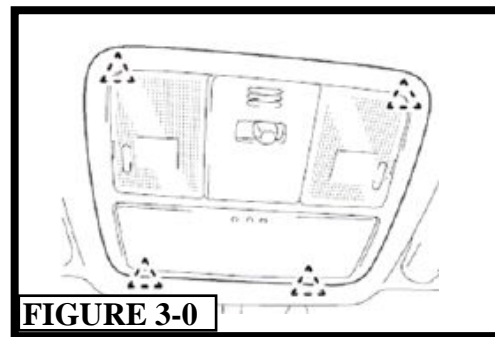

**4. REMOVE DRIVER SIDE SCUFF PLATE AND COWL COVER.**

-  (a). Using a nylon tool, remove scuff plate. **(FIGURE 4-0)**

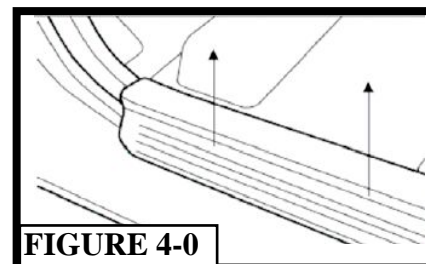

-  (b). Unscrew plastic nut from cowl cover. **(FIGURE 4-1)**

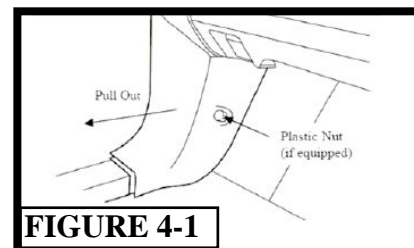



- (c). Grasp rear of cowl cover and pull out towards the rear of vehicle. **(FIGURE 4-1)**

**5. CONSOLE PREPARATION**

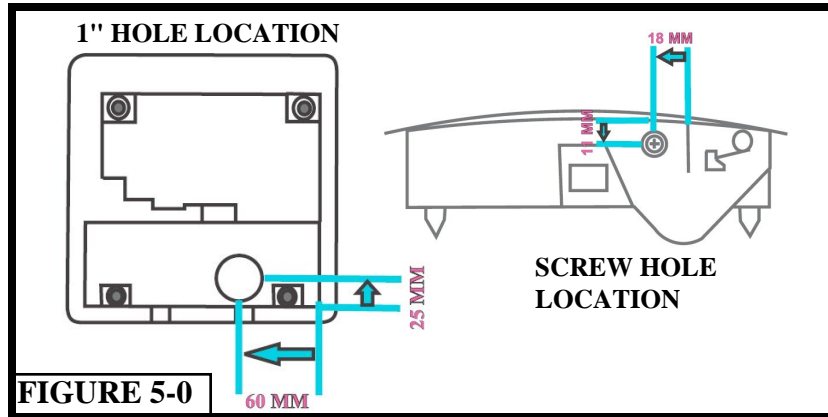
 (a). Using a marking utensil and scale mark 1" hole location on back side of console. Position hole 60 mm to the left from right edge of console and 25 mm from bottom edge of console. **(FIGURE 5-0)**



 (b). Using a marking utensil and scale mark the (2) 10-5/8 screw hole locations. Position hole on the both sides of console 11 mm from top edge and 18 mm towards light assembly from plastic ridge. **(FIGURE 5-0)**

 (c). Drill out harness hole with 1" hole saw. **(FIGURE 5-1)**

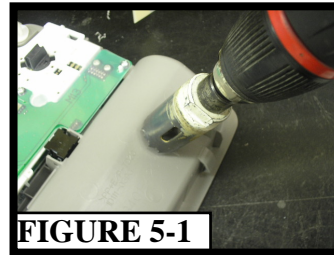

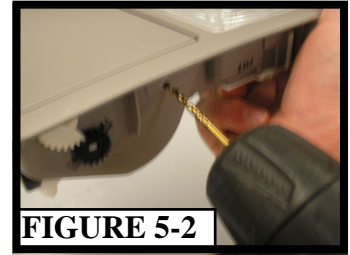

 (d). Place sunglass bin into the closed position. Drill out hole on both sides of console with an 1/8" drill. Run drill through side of console through sunglass bin. **(FIGURE 5-2)**

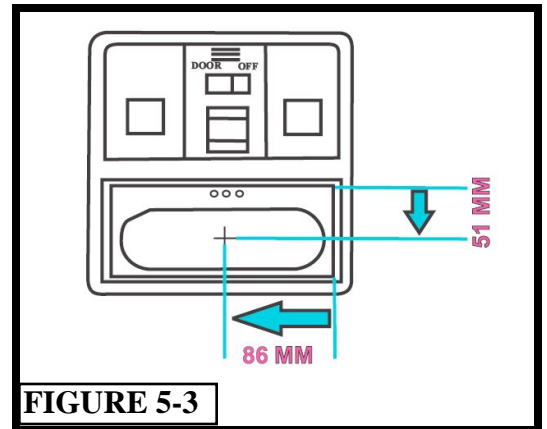

(e). Using a marking utensil and scale mark routing template location on front side of sunglass bin door. Measure and mark a 2" long line 86 mm to the left from the right edge of sunglass bin door. Measure and mark a 2" line 51 mm from the top edge of sunglass bin door. The 2 marks will form an + shape on the sunglass bin door. **(FIGURE 5-3)**



  **Template must be placed at this location to install BlueConnect. Not following these measurements will result in sunglass bin door damage.** 

(f). Remove the self-adhesive backing from the template. Using the center point mark on the template, adhere the template to the console centering it both horizontally and vertically on + shape marked on sunglass bin door. The flat part of oval area goes towards latch on sunglass bin door. **(FIGURE 5-4)**

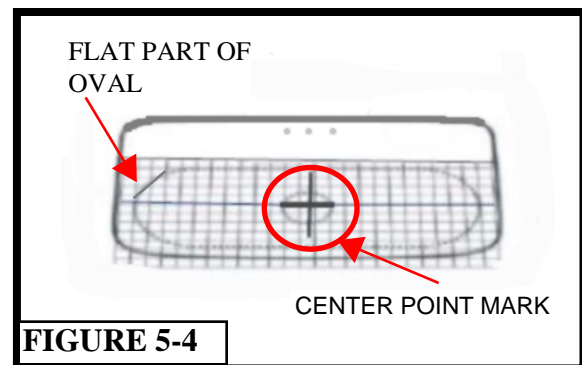

**6. ROUTING OUT HOLE FOR UIB**

(a). Secure the overhead console for cutting. Be careful not to damage the console when securing it. (FIGURE 6-0)

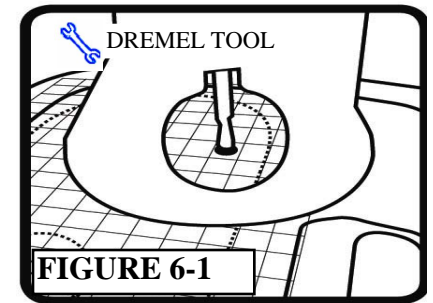
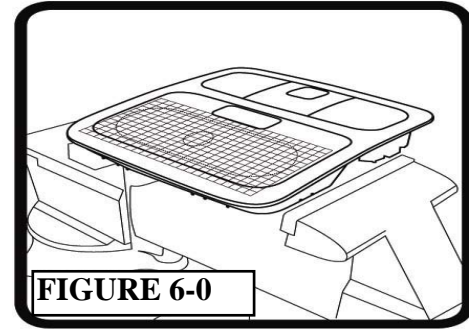

 (b). Using a cutting tool, such as a hand held dremel tool, cut out the area described on the template (the oval area). Start cutting from well inside of the line. (FIGURE 6-1 AND 6-2)

 **DO NOT CUT OUT OUTSIDE OF THE LINE.** 

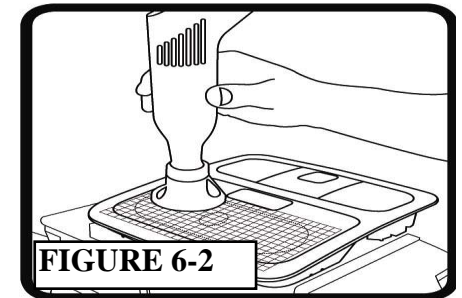

 (c). Any additional trimming or cutting that is needed should be done from the inside of the line. Use a sanding drum to enlarge and smooth the opening as needed. (FIGURE 6-3)

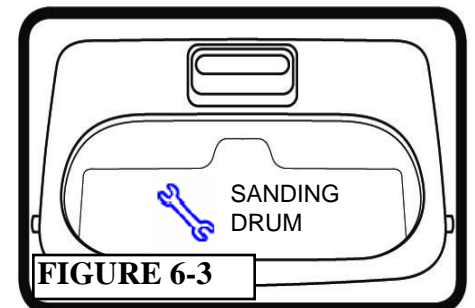

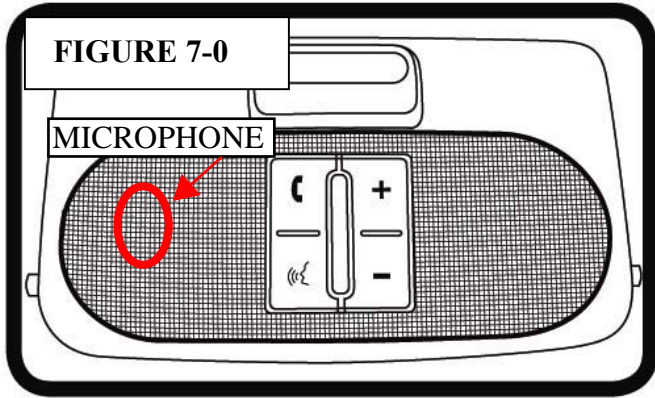

**7. INSERTING THE UIB ASSEMBLY**

(a). Insert the UIB assembly through the opening of the overhead console from the front side. The microphone goes towards driver. (FIGURE 7-0)

**MICROPHONE GOES TOWARDS DRIVER.**

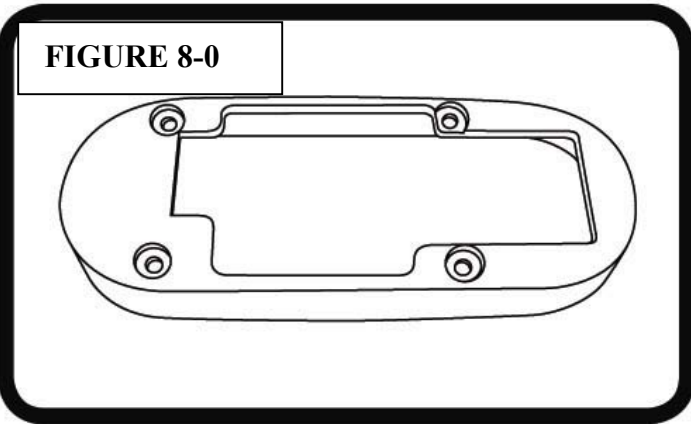

**8. ATTACHING THE UIB ASSEMBLY RETAINER**

(a). The UIB assembly retainer is designed to fit one way. (FIGURE 8-0) It attaches to the back of the UIB assembly from the rear of the opening using the 4 screws supplied. (FIGURE 8-1)

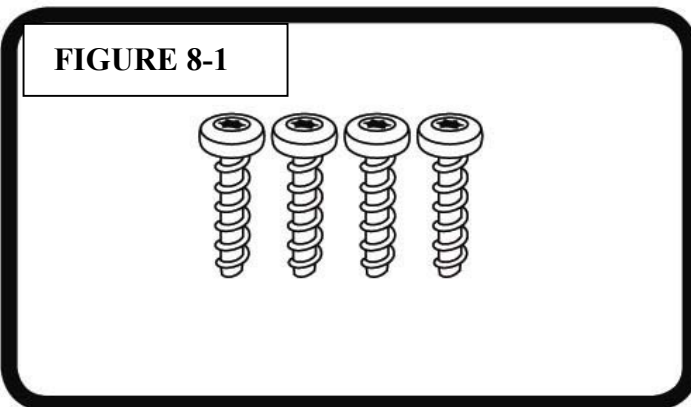

**DO NOT SUBSTITUTE ANY OTHER SCREWS FOR ASSEMBLING THIS UNIT. THE LENGTH, DIAMETER AND THREAD TYPE ARE SPECIFIC FOR THIS APPLICATION. THE USE OF OTHER SCREWS MAY DAMAGE THE HOUSING OR FAIL TO PROPERLY SECURE THE UNIT. NEVER USE AN ELECTRIC DRILL OR CORDLESS SCREWDRIVER TO ASSEMBLE THESE COMPONENTS.**

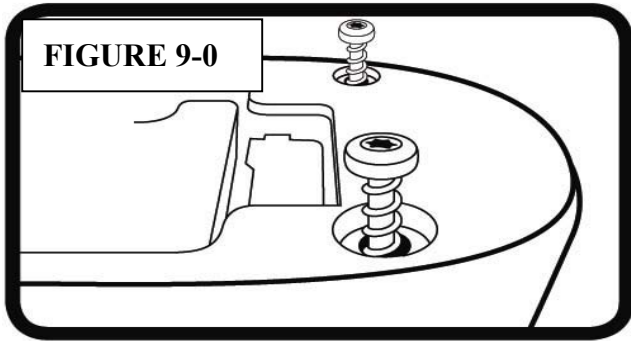

**9. TIGHTEN DOWN RETAINER TO UIB ASSEMBLY**

(a). Insert the 4 screws by hand into the retainer screw holes. (FIGURE 9-0)

(b). Make any final adjustments to the positioning of the UIB assembly. Hold the UIB assembly gently, yet securely, to the installation surface area and begin tightening the screws using a T-15 Torx bit. (FIGURE 9-1)

(c). Tighten the screws ¼ turn at a time to eliminate any gaps where the cover screen contacts the surface or if the unit is loose. Do not over tighten when securing the unit. (FIGURE 9-2)

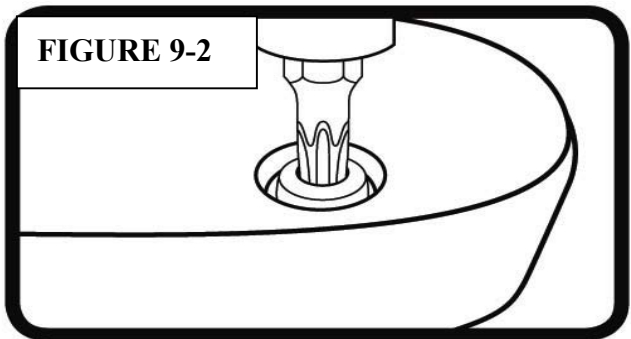
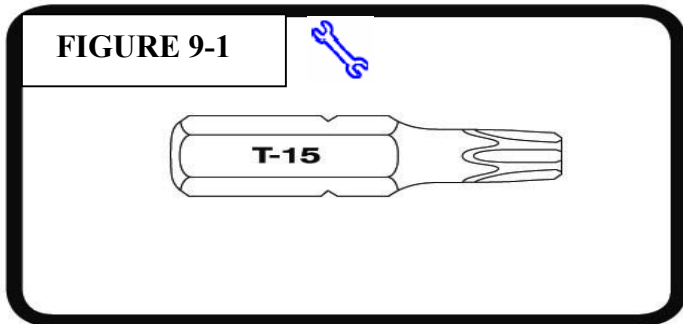

**IMPORTANT – PLEASE READ**

**THERE IS NO NEED TO “CRUSH” THE MATERIAL BETWEEN THE COVER SCREEN AND THE RETAINER.**

**OVER TIGHTENING SCREWS WILL CAUSE DISTORTION AND DISCOLORING OF THE COVER SCREEN.**

**OVER TIGHTENING SCREWS CAN ALSO CAUSE THE OPERATING BUTTONS TO MALFUNCTION.**

**DO NOT USE AN ELECTRIC OR CORDLESS SCREWDRIVER. DO NOT OVER TIGHTEN.**

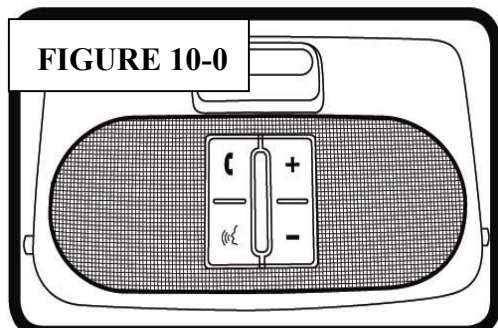

**10. INSPECTION OF THE UIB ASSEMBLY**

(a). Once the UIB assembly is attached and in place, check that it is snug all around its perimeter and secure. Check that each of the UIB buttons operates with a “crisp click” when depressed and recoils to the neutral position quickly and freely. The UIB assembly should be secured without gapping or distorting the cover screen. The microphone should be toward the driver. (FIGURE 10-0)

**11. SUNGLASS BIN CLOSURE**

- (a). Route the wire harness plug into console through 1" opening.
- (b). Plug wire harness into UIB.
- (c). Run (2) 10-5/8 screws into 1/8" holes on side of console after BlueConnect® unit has been installed and is ready to go back into vehicle. **(FIGURE 11-0)**



**12. MODULE BOX MOUNTING**

- (a). Using alcohol water solution clean module box mounting area.
- (b). Remove backing from one side of adhesive tape and apply to non-label side of module box.
- (c). Peel backing tape from module box and mount securely. **(FIGURE 12-0)**

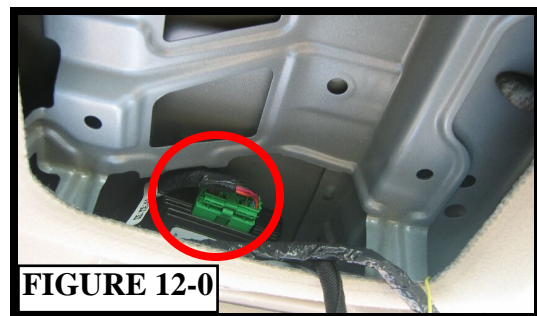

**LABEL SIDE OF MODULE BOX MUST BE POINTING DOWN.**

**MODULE BOX LOCATION: DRIVER SIDE**

**13. WIRE ROUTING (NON-SUNROOF MODELS ONLY)**

- (a). Route yellow accessory wire between vehicle headliner and roof, forward toward A-Pillar.
- (b). Route yellow accessory wire along factory harness, securing with factory harness clips, to A-pillar. Tie strap to factory harness with 2 tie straps. **(FIGURE 13-0)**
- (c). Route yellow accessory wire from main harness down driver side A-pillar to 20 pin connector, located in junction block.
- (d). Remove 10 mm bolt from lower dash trim. Route yellow accessory wire behind lower dash trim fastening point and into cowl area. **(FIGURE 13-1 AND FIGURE 13-2)**

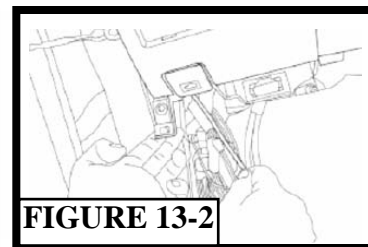
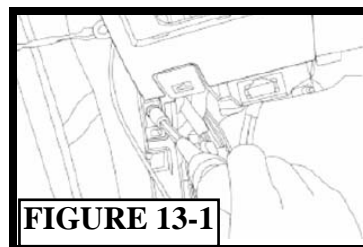
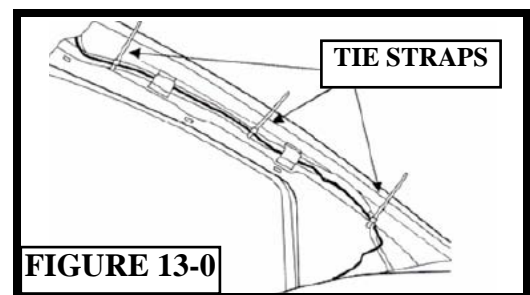

#### 14. OVERHEAD CONSOLE CONNECTIONS

(a). Using T-Tap connect red power wire to pin 6 white/red wire in P5 connector, located in the overhead console dome light assembly. (FIGURE 14-0)

(b). Using T-Tap connect black ground wire to pin 7 white/red wire in P5 connector, located in the overhead console dome light assembly. (FIGURE 14-0)

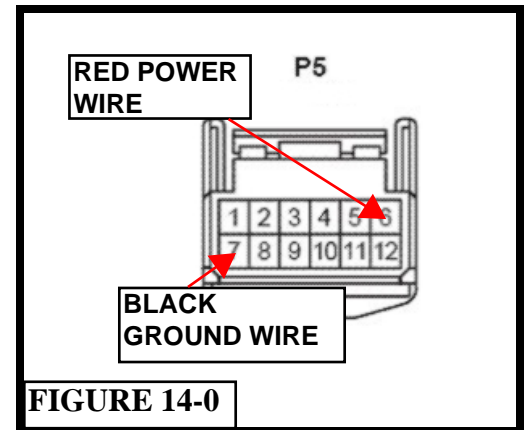

FIGURE 14-0

#### (SUNROOF MODELS ONLY)

(c). Using T-Tap connect yellow accessory wire to pin 5 blue wire in P6 connector, located in sunroof connector. (FIGURE 14-1)

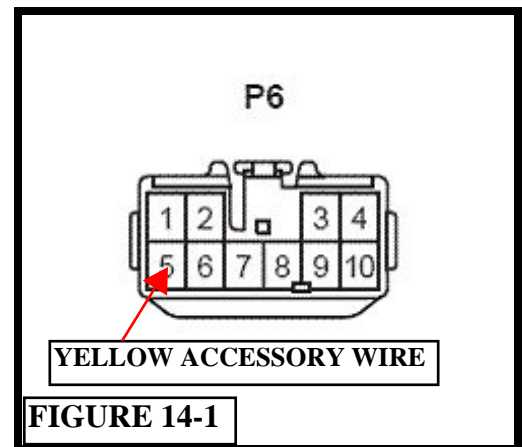

FIGURE 14-1

#### 15. JUNCTION BLOCK WIRE CONNECTIONS (NON-SUNROOF MODELS ONLY)

(a). Using T-Tap connect yellow accessory wire to pin 14 dark blue wire in EK2 connector, located at junction block. (FIGURE 15-0)

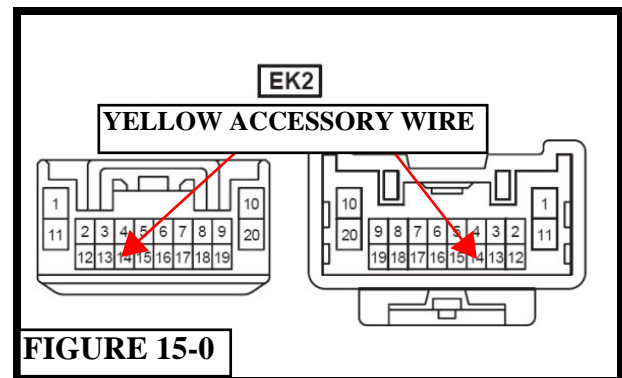

FIGURE 15-0

**USE TIE STRAPS AND FOAM PADS TO SECURE HARNESS AS NEEDED.**

#### 16. REPLACE COWL AREA COVERS AND SCUFF PLATE



(a). Replace 10 mm lower dash trim bolt.

(b). Replace cowl cover and scuff plate.

## 17. REPLACE CONSOLE

- (a). Reconnect all connectors on backside of console.
- (b). Replace console back to its original location.

## 18. COMPLETION

-  (a). Connect negative battery cable and torque to 36" lbs. (FIGURE 18-0) 
-  (b). Place the information booklet and registration card inside the glove compartment after installation.

NOTE: Serial # stickers must match on the information booklet and registration card.

If for some reason the booklet or registration card is damaged the serial # stickers must be removed and placed on the new information booklet or registration card.

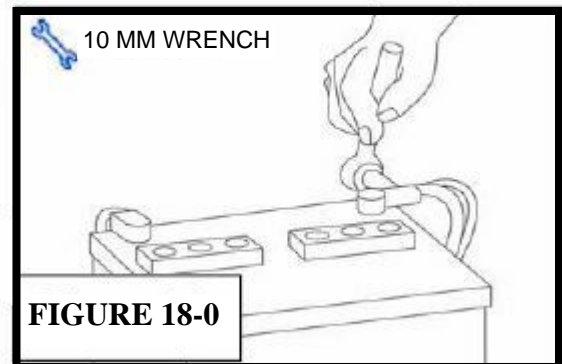

## 19. FUNCTION CHECK

**AFTER ALL PANELS, COVERS, AND COMPONENTS HAVE BEEN REINSTALLED, THAT WERE REMOVED, TEST THOROUGHLY, ALL MECHANICAL AND ELECTRICAL COMPONENTS DISCONNECTED AND OR REMOVED FROM THE VEHICLE DURING THE INSTALLATION OF THIS ACCESSORY.**

- (a). Turn the ignition key to the ACC position. The operating buttons on the BlueConnect® UIB faceplate will be illuminated. Allow 5 seconds for the system to self-check before pushing and releasing the phone button (button #1). The phone button will activate and de-activate the system. (FIGURE 19-0)
- (b). The blue L.E.D. on the circuit board will illuminate the center bar and an audible acknowledgement from the system will be heard.
- (c). BlueConnect® is now ready for the pairing process where it is programmed to communicate with a particular cellular phone. For instructions on the phone pairing process, please refer to the user guide included in the box of contents.

## BlueConnect® UIB (User Interface Board)

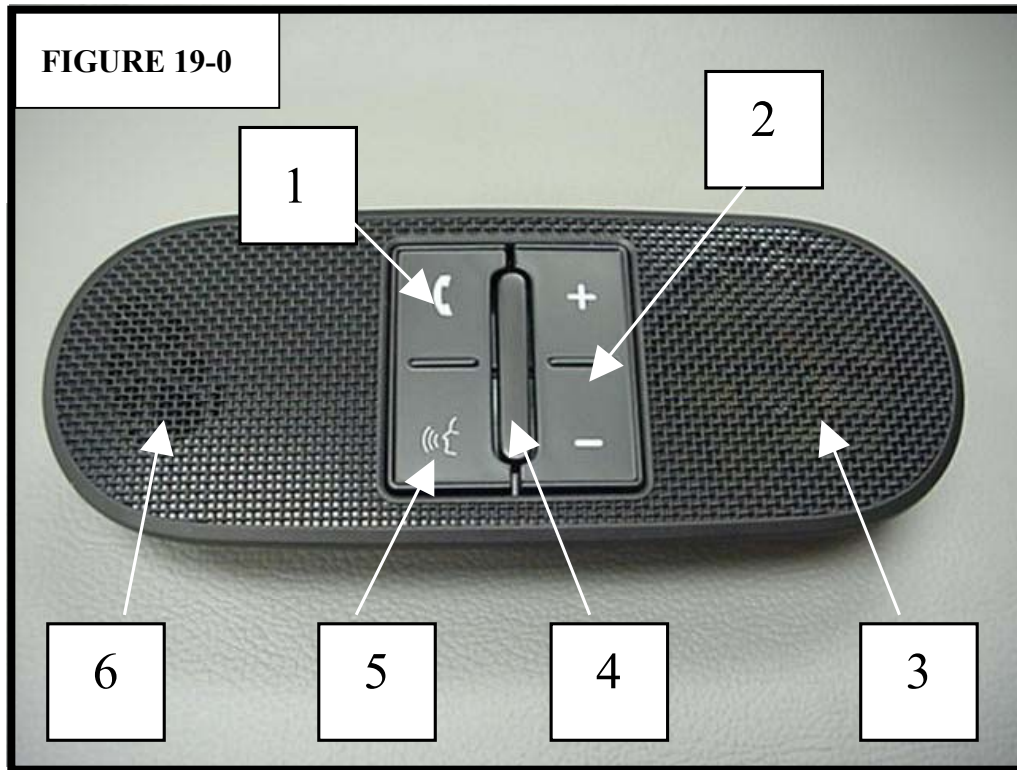

### 1. Phone Button or Activation / Deactivation Button

- o Push to set up and program unit.
- o Push to make a call if not on a call.
- o Push to end a call.
- o Push to accept or reject an incoming call when on another call.

### 2. Volume Up & Down Buttons

- o Push (+) to increase the volume.
- o Push (-) to decrease the volume.
- o Push either button to the desired volume level when the unit is not activated. Audible beeps indicate the current volume level.

### 3. Speaker

### 4. Blue L.E.D. Light

- o A blue light comes on indicating that the unit is activated or when there is an incoming call. It also comes on when you are on a call.

### 5. VR (Voice Recognition) Button or Barge-in Button

- o Push to input a command without having to listen for a prompt.
- o Push to transfer a call. This allows you to transfer your call back to your cell phone in the event you want privacy or are exiting the vehicle.
- o Push to mute the phone.
- o Push to send DTMF tones.

### 6. Directional Microphone